

Hubble Optics Ultra Portable UP 12 Dobsonian instruction manual

Revision: 2.1 06-03-2026

Please read these instructions thoroughly before beginning assembly and subsequent use of the telescope. This manual applies to the UP12 sold after September 2023

1. Unpacking	2
2. Assembly	7
2.1 Install the Secondary Mirror	7
2.2 Assembly of the Dobsonian Rocker	11
2.3 Assembly of the Mirror Box	12
2.3.1 Installation of the Pads and Brass Wires.....	12
2.3.2 Installation of the ALT Bearing.....	14
2.3.3 Installation of the Primary Mirror.....	15
2.3.4 Glue the Primary Mirror For The Air Travel.....	18
2.4 Install the Truss Tubes and Secondary Cage	19
2.4.1 Installation of the Truss Tubes.....	20
2.4.2 Installation of the Secondary Mirror Cage.....	22
2.4.3 Installation of the Optional Finder Scope	23
2.5 Adjust the Sling.....	24
2.6 Balancing The Scope	24
2.7 AZM Tension Spring	25
2.8 Install the iSkyHub-B Digital Setting Circle	25
3. Collimate the Optics.	25
4. Care and Maintenance	28
4.1 Scope and Mirror Storage	28
4.2 Mirror Cleaning	29
5. Specifications	29
6. Limited Warranty	29
7. Technical Support	30

WARNING: Never look at the sun with your telescope without a professionally made solar filter. Permanent eye damage or blindness could result. Eye damage is often painless, so there is no warning until it is too late. Children should not be allowed to handle the telescope. Avoid using the type of solar filter that screws into an eyepiece. They are susceptible to cracking under the intense heat that builds up near

the focus point, and could cause severe retinal damage. Use only the type of solar filter that covers the front of the telescope. Also, be sure to leave the cover caps on the finder scope when solar observing. Better yet, remove the finder scope altogether when viewing the sun.

1. Unpacking

The telescope is packed in two shipping boxes, as described below. We recommend keeping the original packaging for the future usage.

Make sure all the parts in the Parts List are present. Be sure to check carefully, as some parts are very small. If anything appears to be missing or broken, immediately email Hubble Optics for assistance.

Box #1, The UP12 main structure

Quantity	Description
1	Mirror Box/Rocker/Ground board
1	Upper Cage with Focuser L bracket (with 2 M5 x 16 screws)
1	Secondary mirror with the diagonal holder
1	Safety Cage Ring
1	2" 10:1 dual speed focuser
3	Plastic feet with wing nuts
4	M6 knob screws (20mm long) with wingnuts for the truss tube and upper ring connection
8	M6 knob screws for the truss tube and mirror box connection
1	Magic nylon tape to hold the sling
3	Brass wire to evenly separate cell support bars
1	Stainless Steel Cable Sling
6	Mirror Cell Protection Pad
4	Nylon Strip to tie the mirror box to the rocker when needed
2	M5 x40 Socket Head bolts and nuts for the virtual balance
1	M6 plastic wrapped anchoring bolt
8	Truss Tubes (16 sections)

Box #2: The primary mirror

Qty.	Description
1	Primary Mirror

If the optional reusable foams is purchased, the UP12 will be packaged as shown in the following pictures.

- There are 11 layers of foam, each is 50x70x2 cm in size.
- From the bottom up, Layer 1&2 are whole piece of foams

- Layer 3 is for the two ALT bearings
- Layer 4 and 5 are for the ground board and Rocker
- Layer 6-9 are for the mirror box
- Layer 10 is for the upper cage
- The truss tubes are placed between layer 10 and 11
- The Layer 11 is the top piece
- You can cut off some foam to make room for your other accessories, such as eyepiece, finder scope etc.
- You will need to cut and trim the foams around if you want to use the foam to store the scope in a luggage case. A 28" Aluminum frame luggage case, one similar to the pictured (with an outside dimension of about 65 x 47 x 26 cm, handle and wheels are not included in the dimension) is recommended.





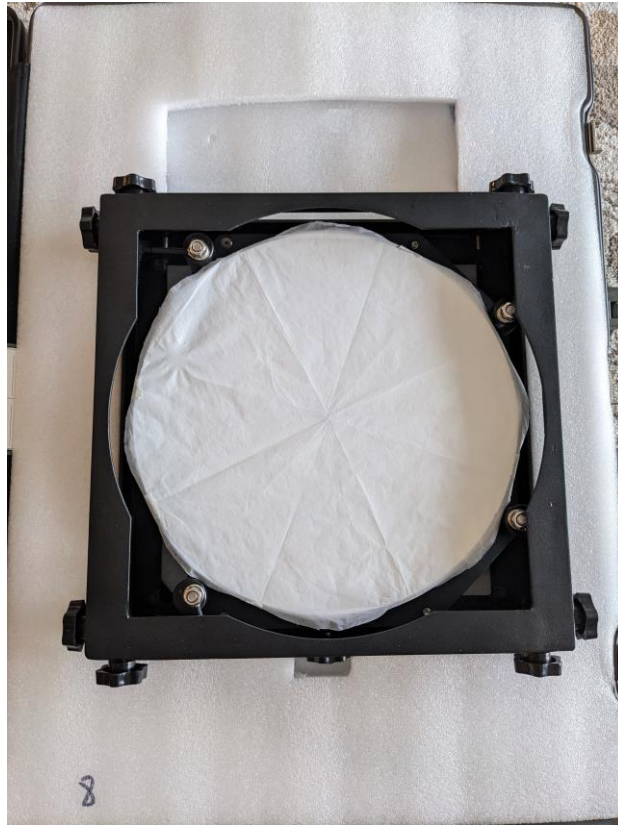



2. Assembly

Now that you have unpacked the boxes and familiarized yourself with all of the parts in front of you, it's time to begin assembly. You'll need a regular screwdriver, a Phillips screwdriver, a set of metric hex keys (1.5, 2, 2.5, 3, 4, and 5mm), one 6-inch (150mm or smaller) adjustable crescent wrenches.



Tools Required (Not provided)

2.1 Install the Secondary Mirror

The secondary mirror is glued to the diagonal holder in the factory and is stored inside a plastic container for protection. You should remove the secondary with the holder from the scope after each usage and store it in the container for protection.

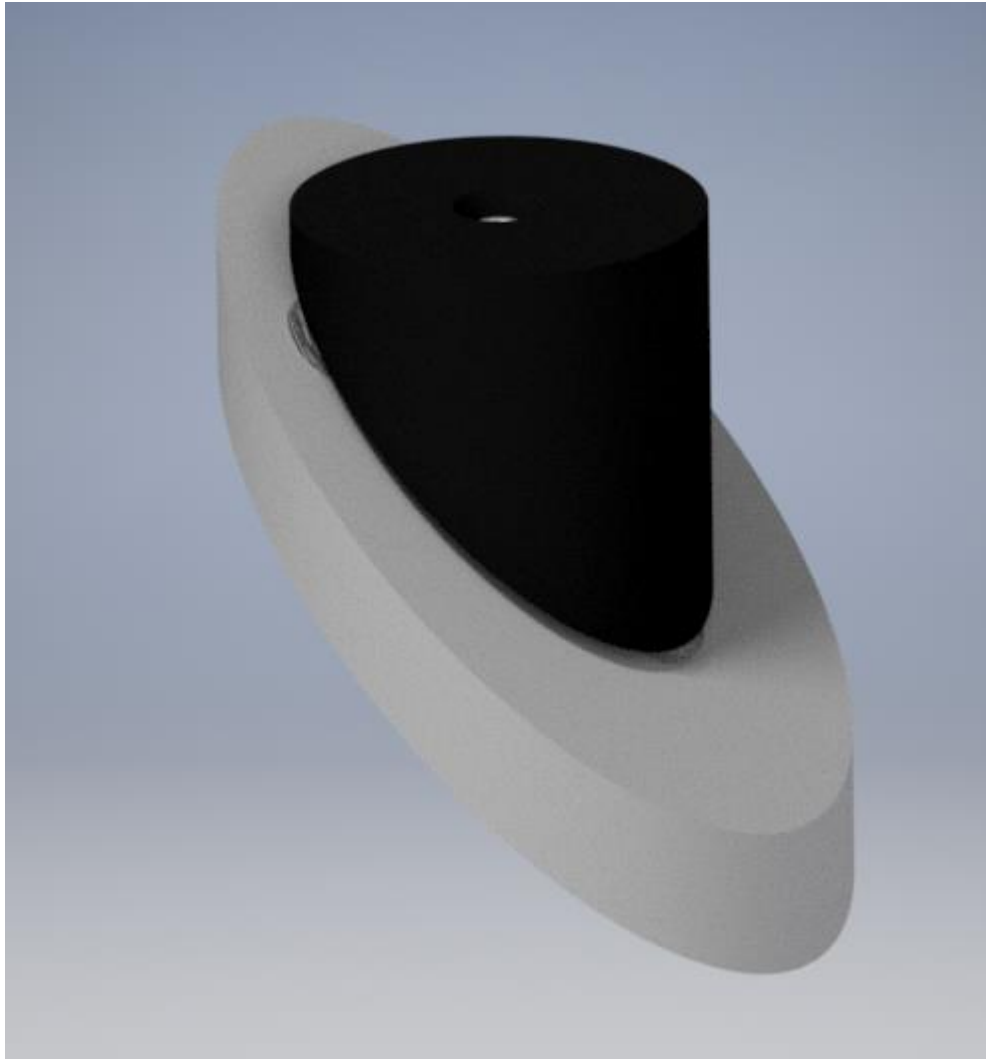

1. **Insert the Central M6 Screw:**
 - First, ensure that the 4 spider wings is securely mounted inside the upper ring.
 - Insert the M6 (35mm long) socket head screw into the spider's central stud.
2. **Attach the Secondary Holder:**
 - Attach the secondary mirror holder onto the M6 screw.
 - Ensure that the secondary mirror, which is already attached to its holder, faces the primary mirror and the focuser.
3. **Roughly Adjust the Secondary Mirror:**
 - Look through the focuser draw tube (without any eyepiece) from the back of the focuser.
 - **Center Bolt Adjustment:** This will move the secondary mirror closer or farther away from the primary mirror. Adjust it so that the secondary mirror's edge is roughly centered in the focuser, viewed from the draw tube without an eyepiece.
 - **Spider Wing Pulling Screws Adjustment:** Adjust these screws to move the secondary mirror left and right. The goal is to ensure that the secondary mirror is roughly centered in the focuser's view.

- **Rotation of the Holder:** If needed, gently rotate the secondary mirror holder around the M6 screw to ensure that the reflective side of the secondary mirror faces the primary mirror.
 - **3 Collimation Screws Adjustment:** These screws allow you to tilt the secondary mirror in various directions. At this point, you're just aiming for a rough alignment where the primary mirror appears centered when viewed through the secondary mirror.
4. **Final Tightening:**
- Once the secondary mirror is roughly centered and aligned, tighten the three collimation screws. Ensure you don't overtighten them as this can strain the secondary mirror or its holder.
 - Tighten all 4 spider wing pulling screws. Again, avoid overtightening.
5. **Final Thoughts:**
- After the initial installation and alignment, you'll likely need to fine-tune the collimation using a collimation tool, like a laser collimator or Cheshire eyepiece, especially if you're using the telescope for astrophotography or high-power visual observations.
 - Always handle the telescope components with care. Avoid touching the mirror surfaces directly, as this can introduce smudges or scratches that degrade optical performance.

Collimating a telescope can seem intimidating at first, but with practice, it becomes a straightforward process. Regularly check the collimation of your telescope, especially if it's transported frequently, to ensure the best possible views of the night sky.

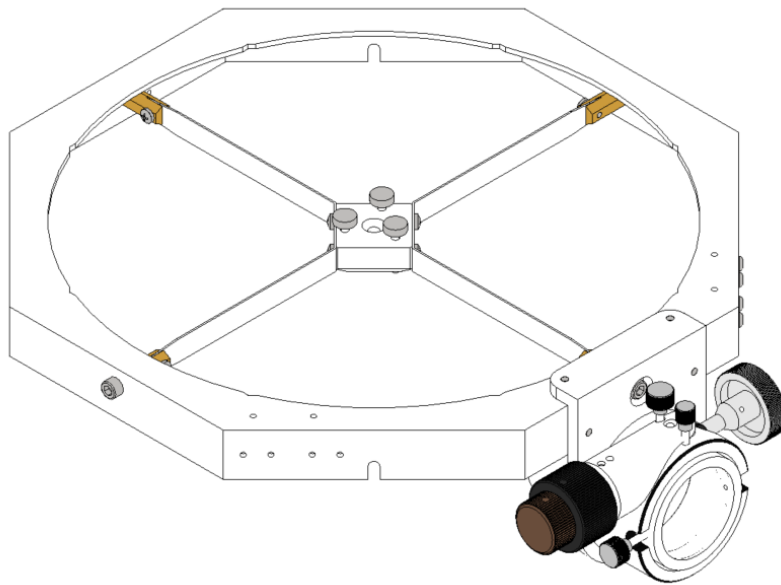

The upper cage without the Secondary Mirror

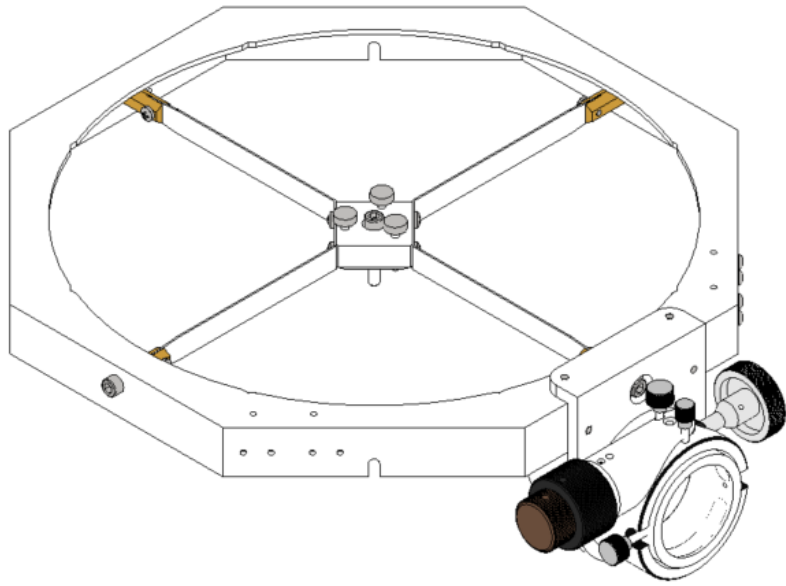

Insert the M6 central bolt is inserted

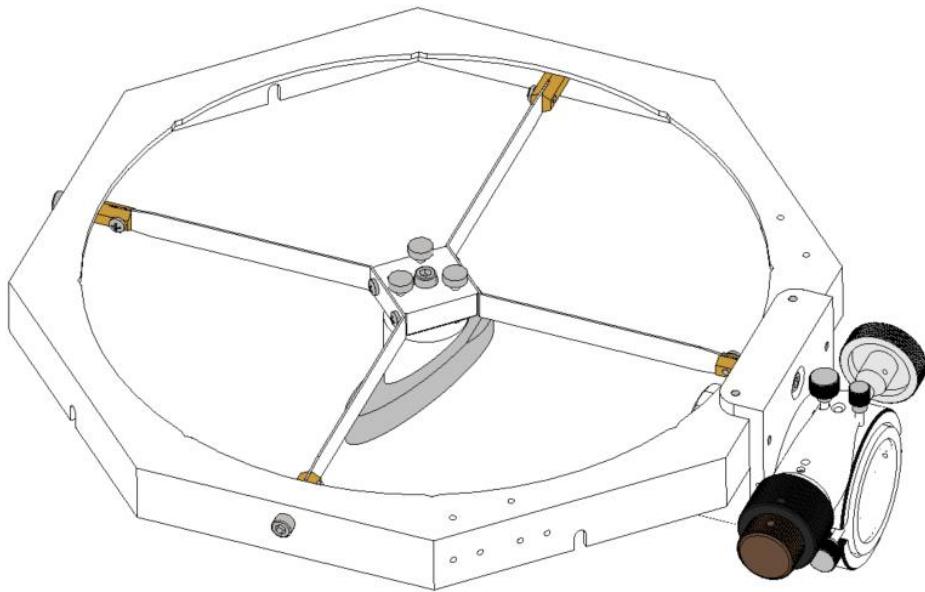

Attach the secondary mirror holder to the central bolt

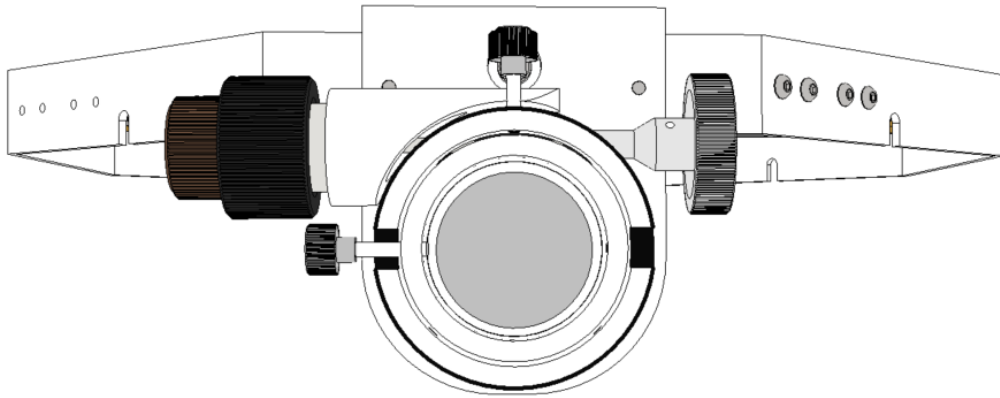

Center the Secondary Mirror in the focuser drawtube

2.2 Assembly of the Dobsonian Rocker

The UP12 base is shipped assembled. The only thing you need to do is to install the three plastic feet each time before usage. Make sure to use the wing nuts to lock the three feet firmly, and make sure do not thread the foot too much to block the rotation of the Rocker.

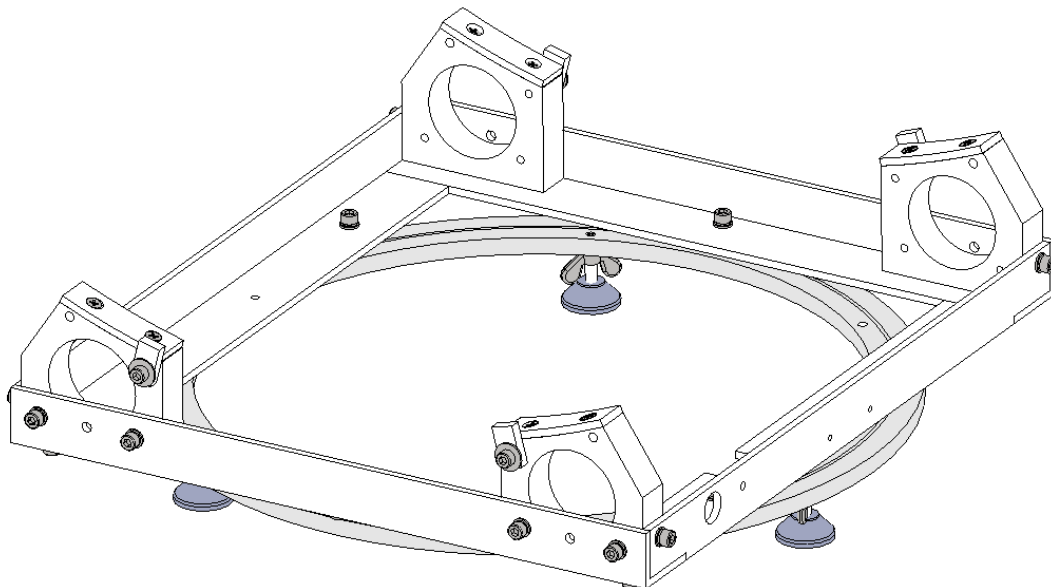

2.3 Assembly of the Mirror Box

The primary mirror is shipped in its own box. Once the primary mirror is installed in the mirror box, there will be no need to remove it until cleaning is necessary. However, for shipping and long-term storage, the primary mirror should be packed tightly in its original packing.

The mirror box is mostly assembled already, but you do need to place the primary mirror into the mirror box.

2.3.1 Installation of the Pads and Brass Wires

Before installing the primary mirror, you need to perform the following tasks:

- Affix the 6 adhesive scratch protectors to the three support bars.
- Affix the three brass wires to regulate the support bars.

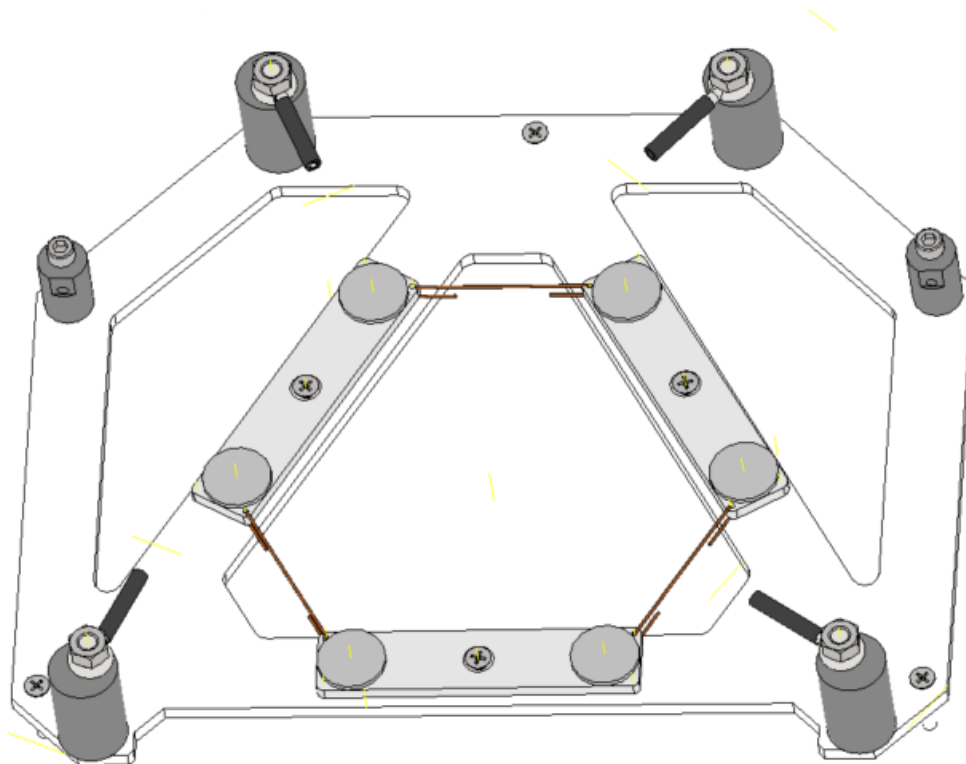

First bend the three brass wires into U shape, with the center portion about 55 mm (a bit longer is OK, but all three should be the same length, as much as possible).

Insert the brass wires into the small holes on the support bars, and then bend brass and twist the head portions to lock the cell bars in the position.

Push the brass wires outward into a slight curve to keep the support bars in position if needed.

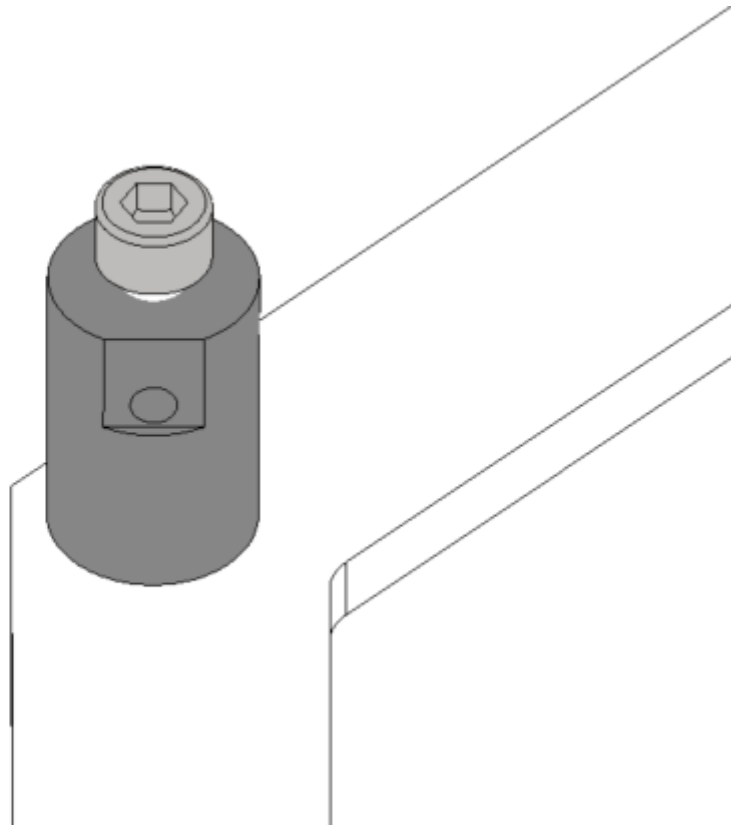

The stainless steel cable anchor post and the top locking screw

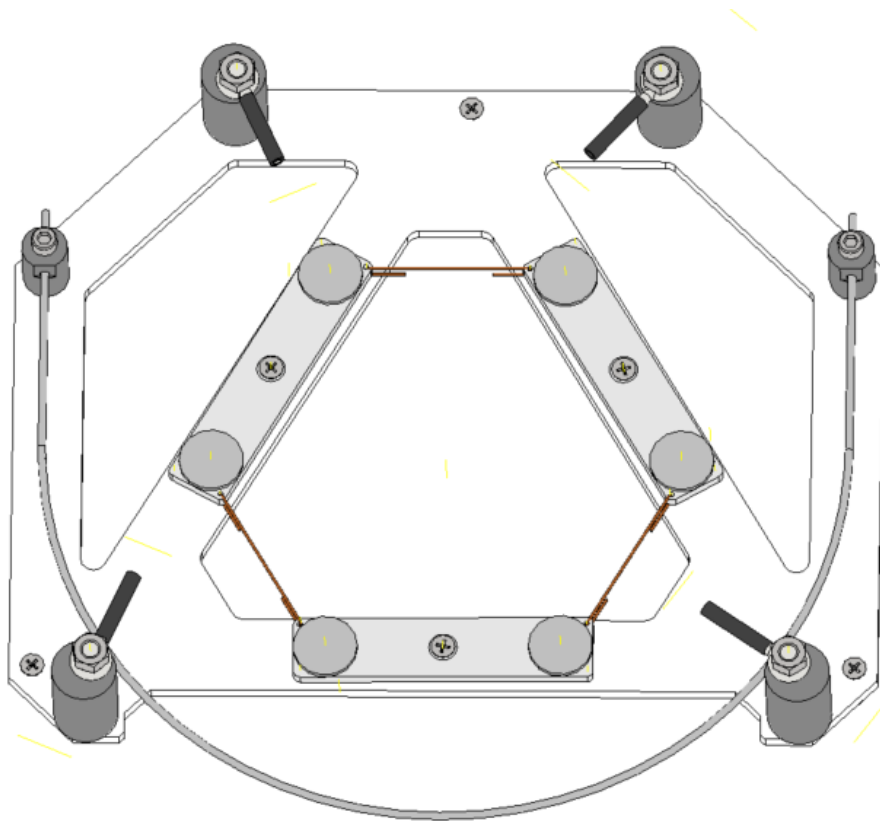

- Loose the two cable sling locking screws, and insert stainless cable sling into the anchor post feed hole and temperately tighten the locking screw to keep the cable sling in place.

2.3.2 Installation of the ALT Bearing

Rest the Mirror Box on a safe place, for example, the packing foam; and then install the two ALT bearing one at a time using the provided M6 blots (25 mm and 40 mm long each) as shown in the following pictures:

Note that you need place the left bearing on the left side and right bearing on the right side of the mirror box, with the side of the bearing with the welted spacers attached to the mirror box.

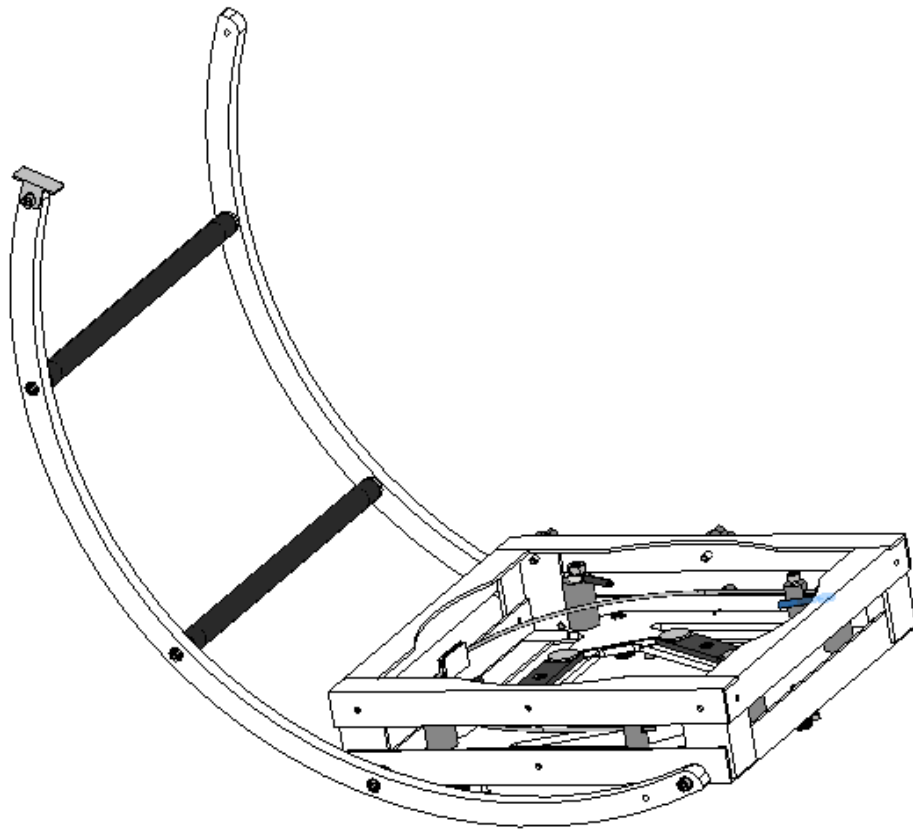

Then rest the mirror box on the Rocker, and you may install the two ALT bearing limit blocks on one of the bearing.

2.3.3 Installation of the Primary Mirror

Rotate the two eccentric side pins and arrange the cable sling to make room for the primary mirror. Loosen the locknuts on the top of the mirror clips and turn them aside.



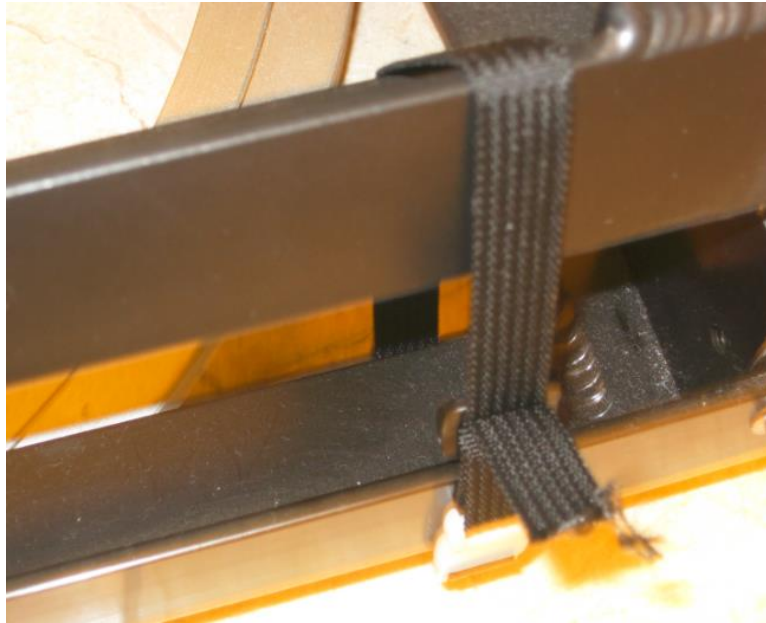

Tie the mirror box to the rocker with nylon strips for the safety

You may tie the mirror box to the rocker with the provided strips for the safety for now.

Rotate the four eccentric side pin outwards to make room for the mirror. Make sure that the three mirror support bars are evenly placed in the cell. Pick up the mirror and place it into the mirror cell. Check that the mirror is centered in the cell. Wiggle it a bit to insure that the cell parts are moving freely and adjusted to the float of the mirror.

Next, lose the sling locking screw to adjust the length of the cable sling between the sling post to make sure the sling snugly supports the mirror when the mirror is centered in the mirror cell; then tighten the locking screws to lock the sling.

The four side pins should not contact the mirror during observation.

The mirror-protecting clips should not contact the mirror at all. Keep the clips about 3-6mm above the mirror surface. Place the mirror clips over the mirror and tighten the top lock nuts.

On the lowest part of the mirror, which will rest in the bottom of the sling, place a short piece of the provided Velcro (Magic Nylon tape)

Make sure the sling is in the middle of the mirror, so there is equal amount of glass above and below it. The magic tape will prevent the sling from slipping off the mirror when the telescope is pointed straight up. Now, leave the sling loose, you will adjust it after the telescope is fully assembled.

- 1. Secure the mirror box to the Rocker with four supplied nylon strips**
- 2. Make sure the 3 support bars are evenly positioned**
- 3. Load the mirror into the cell**

Once the mirror is installed, you should use the square mirror cover (provided) to cover the mirror box to protect the mirror.

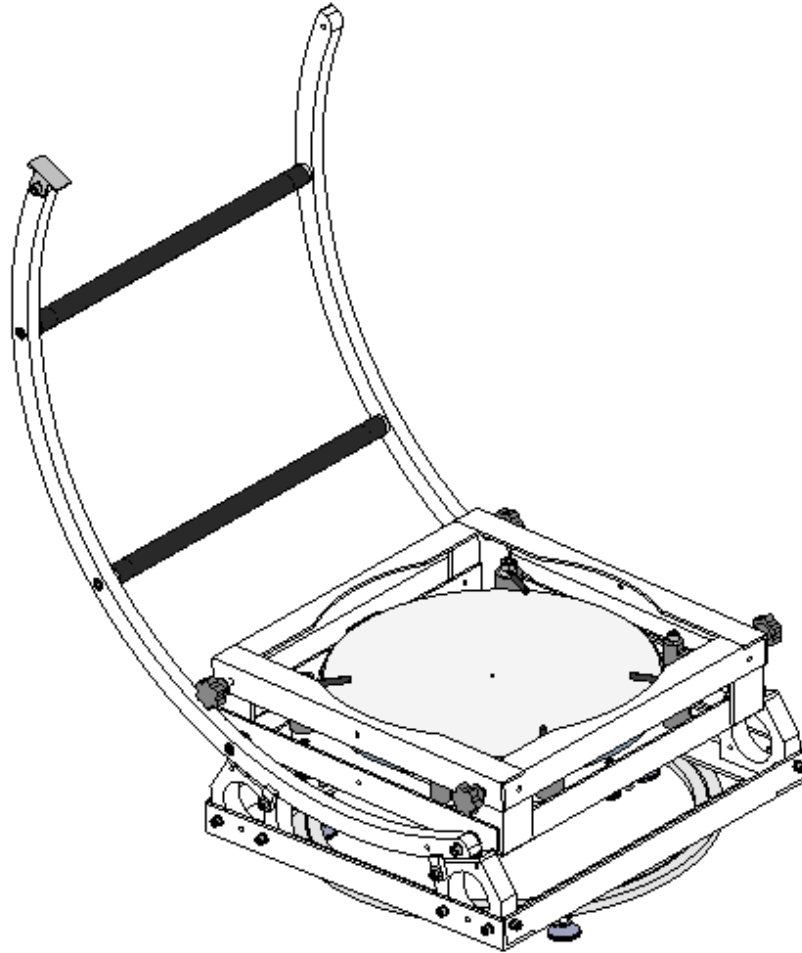

2.3.4 Glue the Primary Mirror For The Air Travel

If you plan to travel with your scope via airline flight, then you are strongly recommended to glue the mirror to the mirror cell using Silicone (The clear GE Silicone II or equivalent is recommended)

- Use 95% or higher grade alcohol to clean the back of the primary mirror and mirror cell support bars (remove the pads first)
- Once they are dried completely after the cleaning, apply silicone to the floatation points on the pivoting bars. Make your best effort to place six blobs

of equal amount of Silicone on the flotation points. Each blob is about 20mm in diameter and 10mm thick.

- Place 6 coins (about 1.5mm thick) on the pivoting bars as the spacers. You can use a few strips of hard cardboard, or even the wooden handles of the ice cream bars as spacers. These spacers should be removed once the silicone is cured. Make sure to leave enough space between the coin and the Silicon blobs, so you don't glue the coins to the cell.
- Make sure the mirror cell is perfectly leveled.
- Carefully place the mirror onto the mirror cell. Make sure that the mirror is perfectly centered in the cell; and make your best effort to not move the mirror once it is placed onto the Silicon.
- Make sure all the pivoting bars are well positioned, minor adjustment might be required if you moved the mirror.
- Again, to make sure the mirror cell and mirror are still leveled.
- Cover the mirror cover and wait for 24 hours to remove all the spacers, and then wait another 48 hours or until the Silicon is completely cured before move or use the scope.

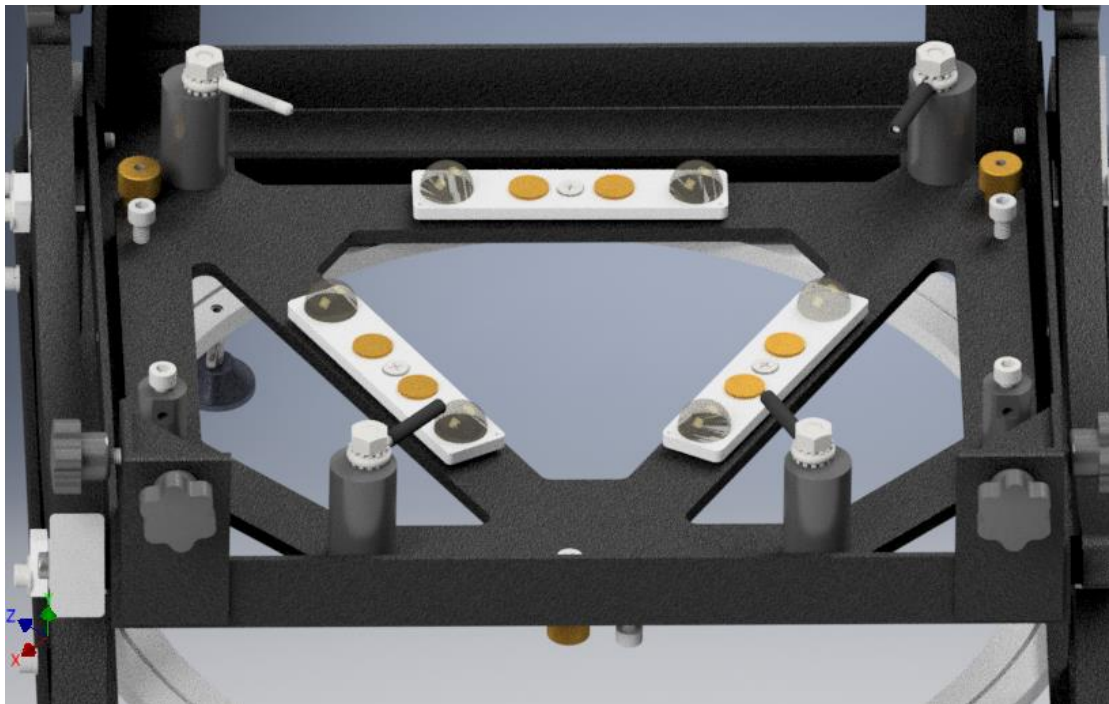

Use 6 coins as the spacers

2.4 Install the Truss Tubes and Secondary Cage

Each full truss tube is made of two half sections, top and bottom sections. You should first thread connect each pair into a full truss tube. After each pair is firmly connected, you should loose the bottom truss angle to align the orientation of the angle with top of the truss tube.

Once each pair of the truss tubes has been aligned, there will be no need to align it again if the same pair is connected. Just to place the truss tube pairs to each other in the truss tube organizer to make sure the same pair will be used the next time.

You can put the truss tube on a table to check and do the alignment.

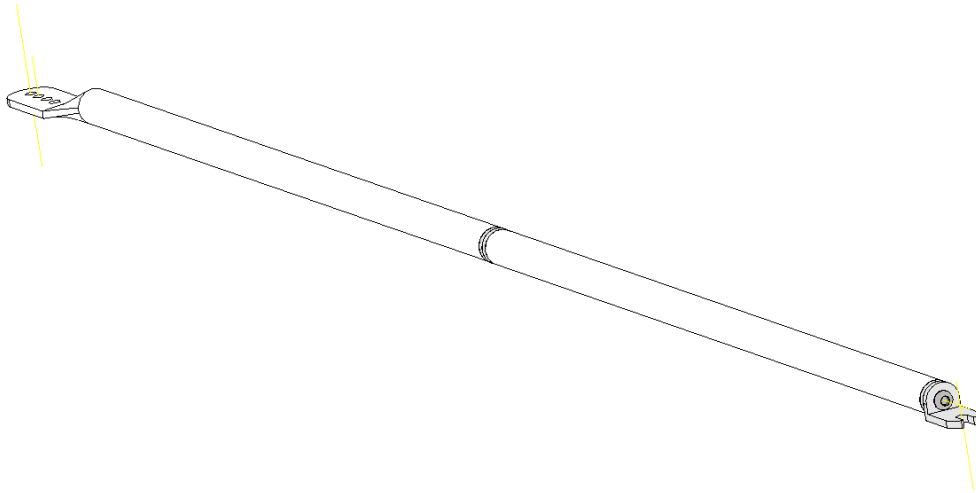

Truss tube misaligned

2.4.1 Installation of the Truss Tubes

The truss tube ends have an asymmetric shape, so they can be connected in the following way to avoid interference with each other.

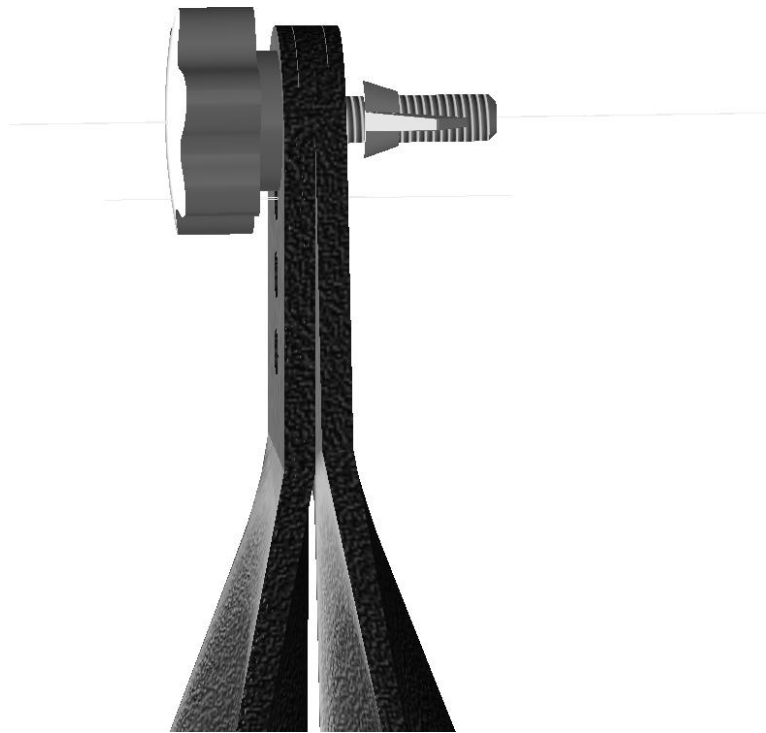

- Make sure that the primary mirror is fully protected with a mirror box cover.
- Connect two truss tubes with an M6 knob screw (35mm long) and an M6 wing nut on the multiple-hole side of the top end. The multiple holes are used for optimizing the OTA length for slight variations in focal length of the primary mirror.
- Then connect each pair of truss tubes to the mirror box with two M6 knob screws (15mm long)

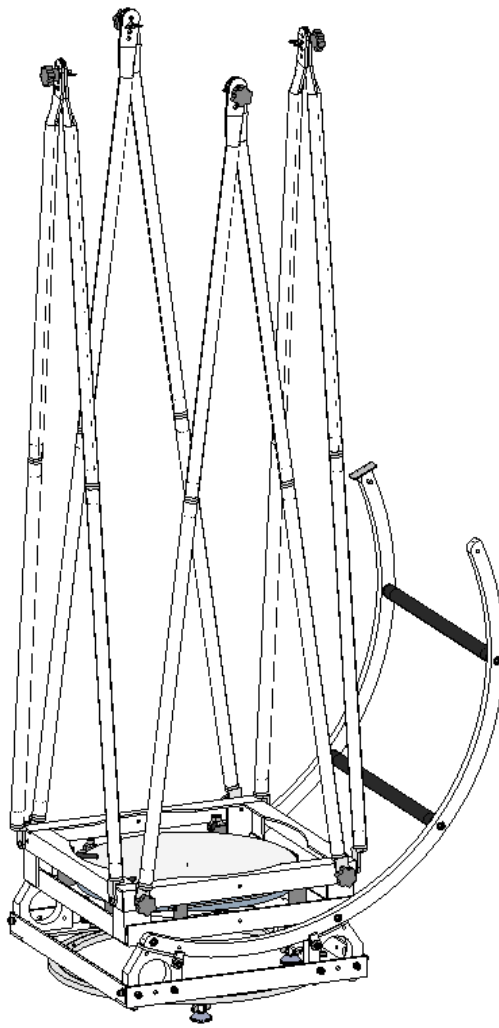

Figure 1: Tighten the knob screws

2.4.2 Installation of the Secondary Mirror Cage

Here is the installation procedure:

- Make sure that the primary mirror is fully protected with a mirror cover.
- Loosen the wing nuts on all the knob screw as much as possible, but make sure they are still fully engaged on the bolts.

- Hold the secondary cage up, and slide one of the slots on the upper ring into the top knob bolt of one truss pair. Make sure you slide the slot into the space between wing nut and the truss tube ends.
- Then slide an adjacent slot into the knob bolt of the corresponding truss pair.
- Then slide the remaining two slots into the rest two knobs bolts at the same time
- Finally tighten all knobs & wing nuts.

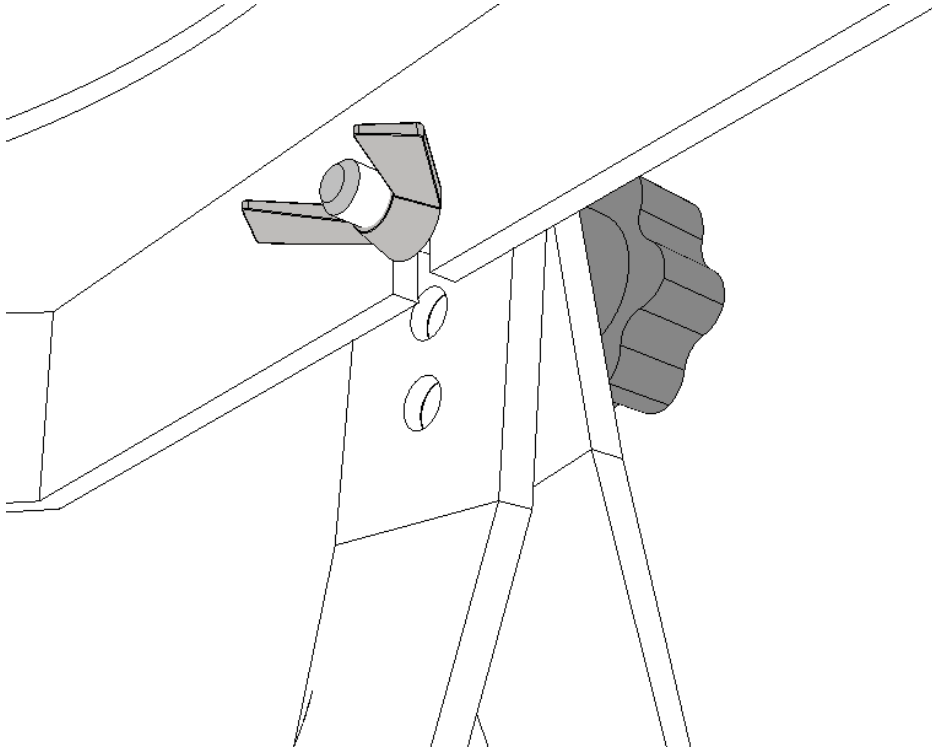
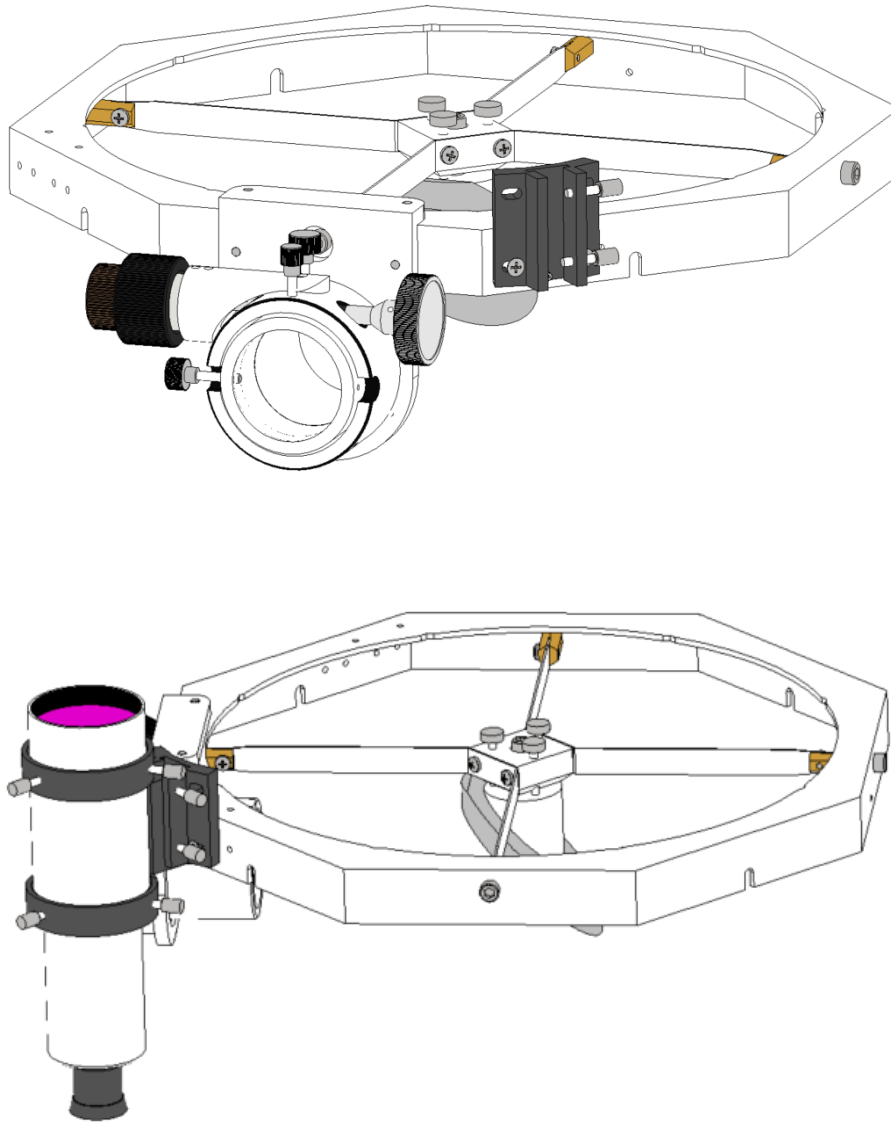

Figure 2:Slide in one slot first (a picture of an UL14)

2.4.3 Installation of the Optional Finder Scope

Use 2 provided (hexagon or cross) socket sunk head screws to mount the finder scope via two of the four finder base mounting holes.



2.5 Adjust the Sling

After the UP12 is fully assembled, in order to center the primary mirror, the sling must be adjusted if you have not done it already.

2.6 Balancing The Scope

The UP12 telescope's ALT (altitude) bearing is engineered to self-balance the scope under typical payload conditions. This means that in most standard viewing scenarios, users won't have to add any counterweights to the mirror box to maintain balance. However, should you attach an unusually heavy payload to the focuser, additional counterbalancing might be necessary. It's worth noting that counterweights are not provided with the telescope, so users will need to source them separately if required.

2.7 AZM Tension Spring

A tension adjustable spring has been installed to suit the personal preference of each observer with a simple tension adjustment bolt.

2.8 Install the iSkyHub-B Digital Setting Circle

You can attach the iSkyHub-B on one of the ALT bearing as pictured below. Refer to the iSkyHub-B manual for detailed instruction.

3. Collimate the Optics.

Collimating a telescope can seem intimidating at first, but with practice, it becomes a straightforward process. Regularly check the collimation of your telescope, especially if it's transported frequently, to ensure the best possible views of the night sky.

Keep the primary mirror covered during step 1. Point the telescope to an angle about 60 degrees above the horizontal during collimation steps 1-3.

Ensure that UP12's collimation doesn't shift when pointed at different altitudes. Tighten all locking nuts and screws properly along the entire optical path:

- Ensure the focuser is tightened firmly in its base.
- Ensure the focuser base is securely fastened to the upper ring.
- Ensure all four spider vanes are securely fastened to both the spider hub and the upper ring.
- After collimation, the three collimation screws for the secondary mirror should be properly tightened.
- All knob screws for all the truss tubes need to be securely tightened.
- The three primary mirror cell lock screws need to be tightened properly.

Step 1: Center the secondary mirror along the axis of the focuser drawtube.

For this step, use a simple collimation cap (or sight tube). Insert the cap into the focuser and look through the peephole of the sight tube at the secondary mirror. If you

don't have a collimation cap or sight tube, you can approximate by eyeballing from a distance, positioning your eye centered with the drawtube.

The secondary mirror should appear round and be exactly centered within the sight tube. If it is, then Step 1 is complete. If not, adjustments might be needed for either the secondary holder, the focuser, or both.

Begin by checking and adjusting the secondary holder. If the error is vertically up or down, adjust the central bolt that connects the holder to the spider hub.

If the discrepancy is to either side of the focuser (perpendicular to the optical axis), examine if the secondary holder is centered within the upper ring. If it's off-center, adjust the spider wing's pulling screws until it's centered.

Step 2: Adjust the tilt of the secondary mirror to direct the focuser's axis toward the center of the primary mirror. To start, remove the cover from the primary mirror.

For this step, you'll need a laser collimator. Insert the laser collimator into the focuser tube. Adjust the three secondary mirror collimation screws until the laser beam is centered on the primary mirror's center spot.

A slight misalignment in the secondary mirror is typically not problematic. As long as the pointing error remains within 1 or 2 percent of the main mirror's diameter, it won't cause any noticeable differences.

Step 3: This step is crucial. Here, you'll adjust the tilt of the primary mirror to ensure the returning laser beam centers on the centre of the laser collimator.

Manipulate the three primary collimation screws and their adjacent locking screws to align the laser's returning beam with the collimator's faceplate.



Figure 3: The primary mirror is not yet collimated.



Figure 4: The primary mirror is perfectly collimated by laser collimator.

Step 4: Star-Testing Your Collimation

You may use star test to verify the collimation of your scope.

Aim the telescope at a bright star. Defocus the star until it becomes a donut looking ring. If the donut hole looks centered (in the center of the donut), the scope is perfectly collimated. If the donut hole is not centered, adjust the primary collimation screws in such way so that the defocused star moves in the direction of the fat side of the donut as shown in the following figure. Re-center the star and repeat this process until the donut hole looks centered as shown in the following figure.

..

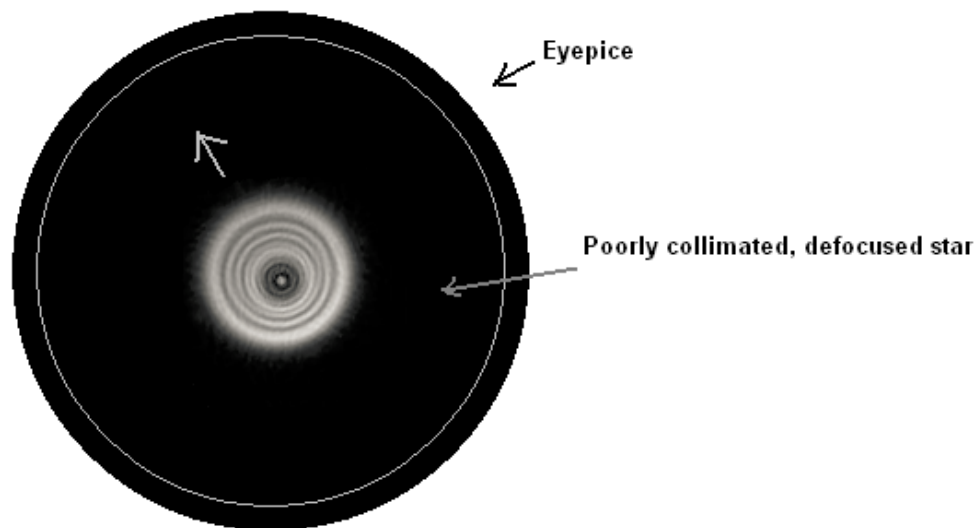

It's advisable to carry out this procedure at the onset of each observing session. Additionally, you should check the collimation sporadically throughout the night. This is crucial because factors like temperature variations or routine handling could cause shifts in your telescope's components, potentially affecting the collimation.

4. Care and Maintenance

4.1 Scope and Mirror Storage

The UP12G should be stored in a clean, dry, dust-free place, safe from rapid changes in temperature and humidity. Do not store the telescope outdoors. The scope is best stored in our optional luggage case.

4.2 Mirror Cleaning

You should not have to clean the mirror often. The best thing you can do to keep your mirror is to prevent it from getting dirty in the first place! A simple air-blow cleaning, using an optical air dust blower is the next best thing you can do.

5. Specifications

Optical design : Reflector

Optical diameter : 304.8mm

Focal length : 1372mm

Focal ratio : f/4.5

Optics type : Parabolic

Eyepieces: Not included

Optical quality : Diffraction limited++ (Strehl 0.95+ for the Primary, 1/10 lambda or for the secondary mirror)

Focuser : 2" low profile 10:1 dual-speed linear bearing Crayford focuser

Secondary mirror obstruction : 60 mm

Secondary mirror obstruction by diameter : 19.7%

Secondary mirror obstruction by area : 3.9%

Mirror coatings/over-coatings : 96% Semi-Enhanced Aluminum coating on the primary and 96% Enhanced coating on the secondary mirror

Materials : Aluminum Alloy (T6063-T6) tube with black knob screws, T6061-T6 structure.

Weight, fully assembled : 32 lbs.

Optional accessories : 8x50 Illuminated Finder Scope, Red Dot Finder Scope, Shroud, Vinyl foam Cushioned Grips

Other features : Stainless Steel Cable Sling lateral support and deluxe push-pull brass knob collimation screws, two of them are front accessible.

6. Limited Warranty

Hubble Optics (Optel Engineering Group Inc.), Seller, warrants to the original purchaser only, that goods sold will be free of material defects in design, materials and workmanship for a period of one year following the date of shipment by Seller to Buyer. Seller will repair or replace, or refund the purchase price as to, goods that do not conform to the foregoing warranty, provided the cause of the nonconformity does not arise from or relate to modification, misuse, or abuse by the customer, and provided a warranty claim, stating in writing and with reasonable particularity the claimed nonconformity, and the goods, are delivered to Seller within the one year period. Repair or replacement of the product or refund of the purchase price, at Seller's sole option, shall be the Buyer's exclusive remedies. Seller shall not be responsible for any indirect, special or consequential damages arising from use of the products. This warranty is given in lieu of any other warranties, express or implied, including of performance, merchantability, fitness for particular purpose, or arising

from course of dealing or usage of trade. Goods subject to this warranty must be shipped postage pre-paid by Buyer to the Seller. Some states do not allow the exclusion or limitation of incidental or consequential damages, so the above limitations may not apply to you. This warranty gives you specific legal rights, and you may also have other rights, which vary from state to state.

7. Technical Support

Hubble Optics (Optel Engineering Group Inc.) will provide the support for the basic operations outlined in this document by email. You will receive a response, generally within 24 hours.