

# Hubble Optics Ultra Light UL 24G Dobsonian Assembly instruction manual

REV: 06-03-2026

Please read these instructions thoroughly before beginning assembly and subsequent use of the telescope.

<b>1. Unpacking</b> .....	<b>2</b>
<b>2. Assembly</b> .....	<b>5</b>
2.1 Install the Secondary Mirror .....	6
2.1.1 Install the Secondary to the diagonal holder.....	6
2.1.2 Assembly of the Secondary Cage .....	7
2.2 Assembly of the Dobsonian Rocker .....	11
2.3 Assembly of the Mirror Box .....	15
2.3.1 Install the ALT bearings. ....	16
2.3.2 Install the Primary Mirror .....	21
2.4 Install the Truss Tubes and Secondary Cage .....	27
2.4.1 Installation of the Truss Tubes.....	27
2.4.2 Installation of the Secondary Mirror Cage.....	28
2.4.3 Installation of the Optional Finder Scope .....	31
<b>3. Balance the scope</b> .....	<b>31</b>
<b>3. Connect the GoTo wirings</b> .....	<b>32</b>
<b>4. Collimate the Optics.</b> .....	<b>33</b>
<b>5. Care and Maintenance</b> .....	<b>36</b>
5.1 Mirror Storage.....	36
5.2 Mirror Cleaning .....	37
<b>6. Specification</b> .....	<b>37</b>
<b>6. Limited Warranty</b> .....	<b>37</b>
<b>7. Technical Support</b> .....	<b>38</b>

**WARNING: Never look at the sun with your telescope without a professionally made solar filter. Permanent eye damage or blindness could result. Eye damage is often painless, so there is no warning until it is too late. Children should not be allowed to handle the telescope. Avoid using the type of solar filter that screws into an eyepiece. They are susceptible to cracking under the intense heat that builds up near the focus point, and could cause severe retinal damage. Use only the type of solar filter that covers the front of the telescope. Also, be sure to**

***leave the cover caps on the finder scope when solar observing. Remove the finder scope altogether when viewing the sun.***

## **1.Unpacking**

The UL24G telescope is packed in 4 shipping boxes, as described below. You are recommended to keep the original packages for the future usage.

Make sure all the parts in the Parts List are present. Be sure to check all boxes carefully, as some parts are very small. If anything appears to be missing or broken, immediately email Hubble Optics for assistance.

**Box #1:** the UL24G Primary Mirror

Primary Mirror

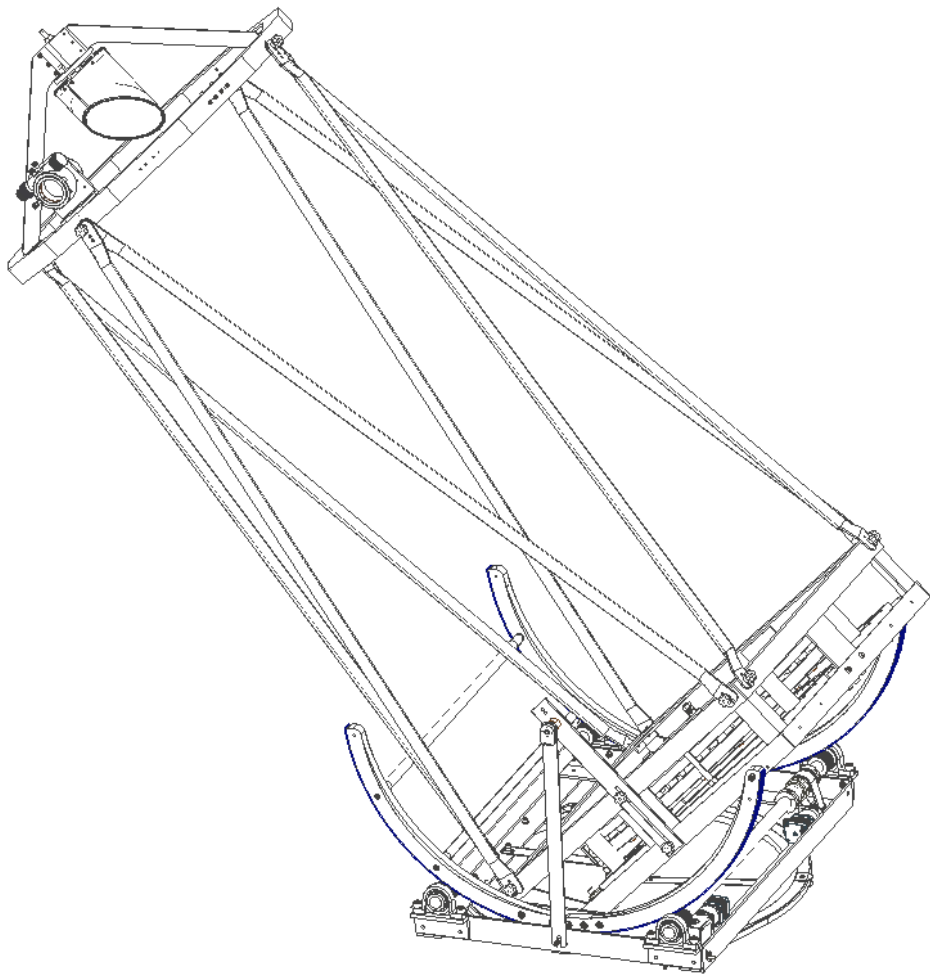
**Box #2:** The Rocker/Ground board/Upper Cage/Accessories/GoTo Controller



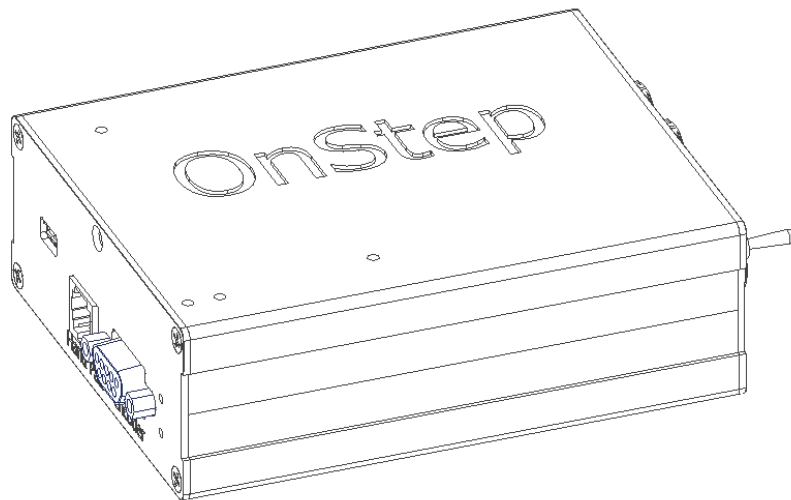
**Box #3:** Mirror Box

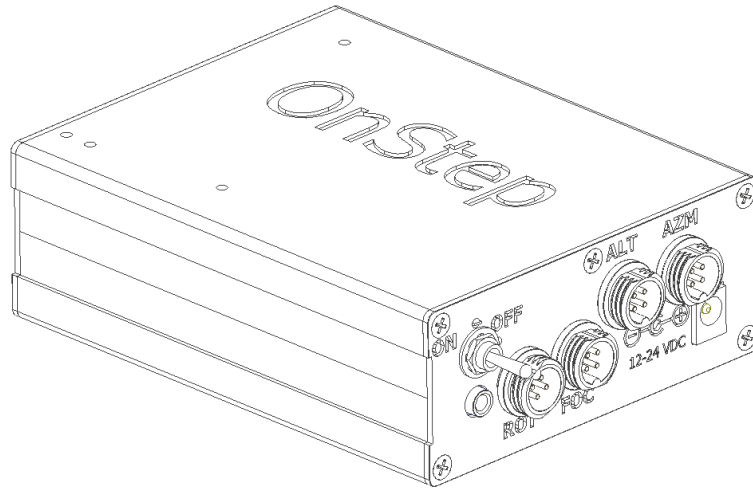
**Box #4:** Truss Tubes

<b>Quantity</b>	<b>Description</b>
1	Rocker/Ground board
1	GoTo Controller
2	Motor Cables
1	Encoder DB9 Y cable
1	AZM encoder brackets (installed)
1	AZM encoder assembly
1	ALT encoder bracket
1	ALT encoder assembly
1	GoTo Smart Hand Controller and RJ12 6P5C Cable
1	Upper ring
3	Spider Vanes
1	Secondary spider hub and the secondary mirror holder
1	Focuser L bracket (with 2 M5 x 16 screws)
1	PP Mirror Cover (optional)
1	127mm Secondary mirror
1	2" 10:1 dual speed focuser
3	Scope Feet
9	Brass wire to evenly separate cell support bars
18	Mirror Cell Support Pad

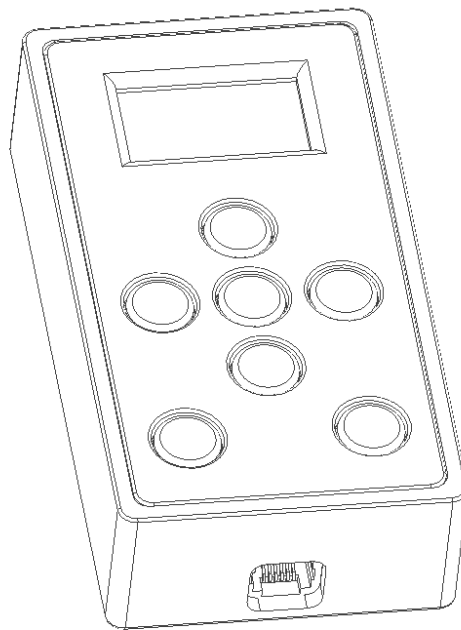


**Figure 1: UL24G**





**Figure 2: GoTo Controller**



**Figure 3: GoTo Smart Hand Controller**

## **2. Assembly**

Now that you have unpacked the boxes and familiarized yourself with all the parts in front of you, it's time to begin assembly. You'll need a regular screwdriver, a Phillips screwdriver, a set of metric hex keys (1.5, 2, 2.5, 3, 4, and 5mm), two 6-inch (150mm or smaller) adjustable crescent wrenches, and a scissor.



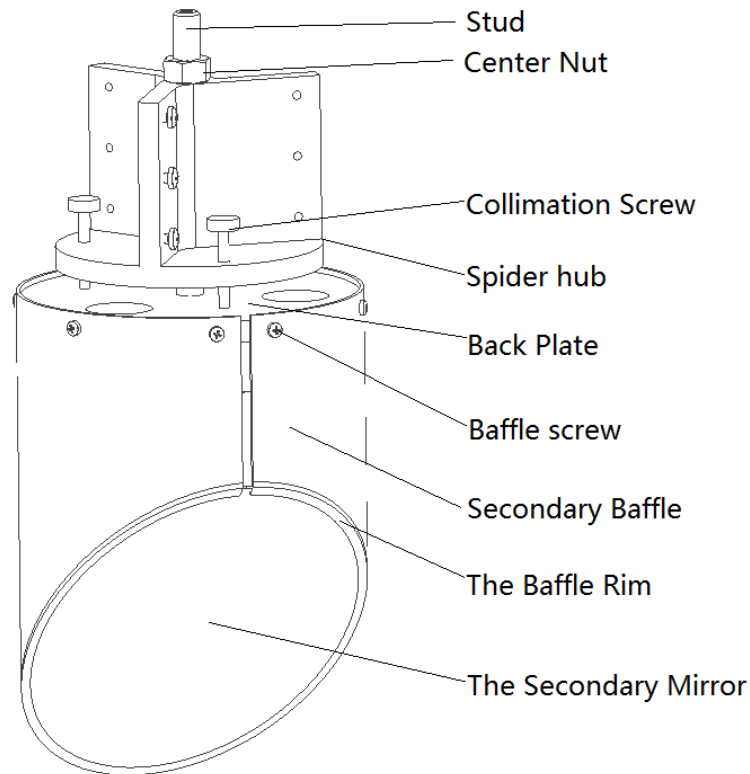
**Figure 4: Tools Required (Not provided)**

## **2.1 Install the Secondary Mirror**

### **2.1.1 Install the Secondary to the diagonal holder**

The secondary baffle is made of the thin aluminum, please handle the mirror and the baffle with care! First, remove the 5 small side screws holding the secondary baffle. Open the baffle slightly, and carefully slide the secondary mirror into the baffle from the back; let the mirror lightly held by the baffle's rim. Then place the fiber fill behind the secondary mirror to support the mirror. You should place enough fiber packing behind the secondary to hold it snugly in place but don't over-pack it; otherwise, it will cause distortion of the secondary mirror. Then re-install the 5 small screws to secure the baffle and the secondary mirror to the back plate.

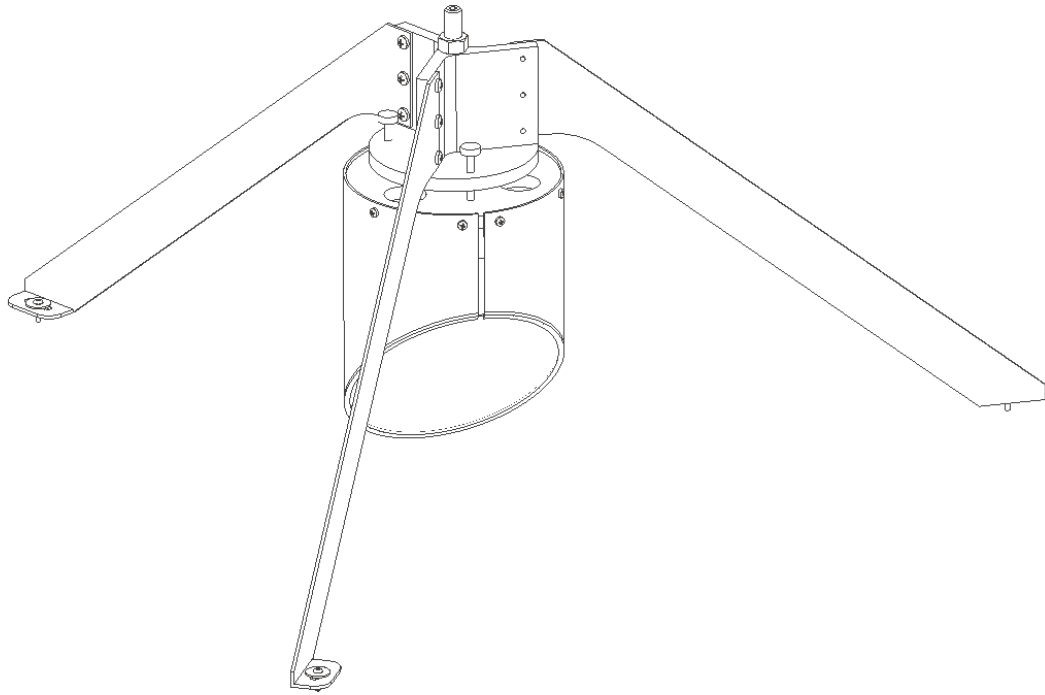
You may need to add some spacers between the baffle and the back plate if the baffle is too tight.



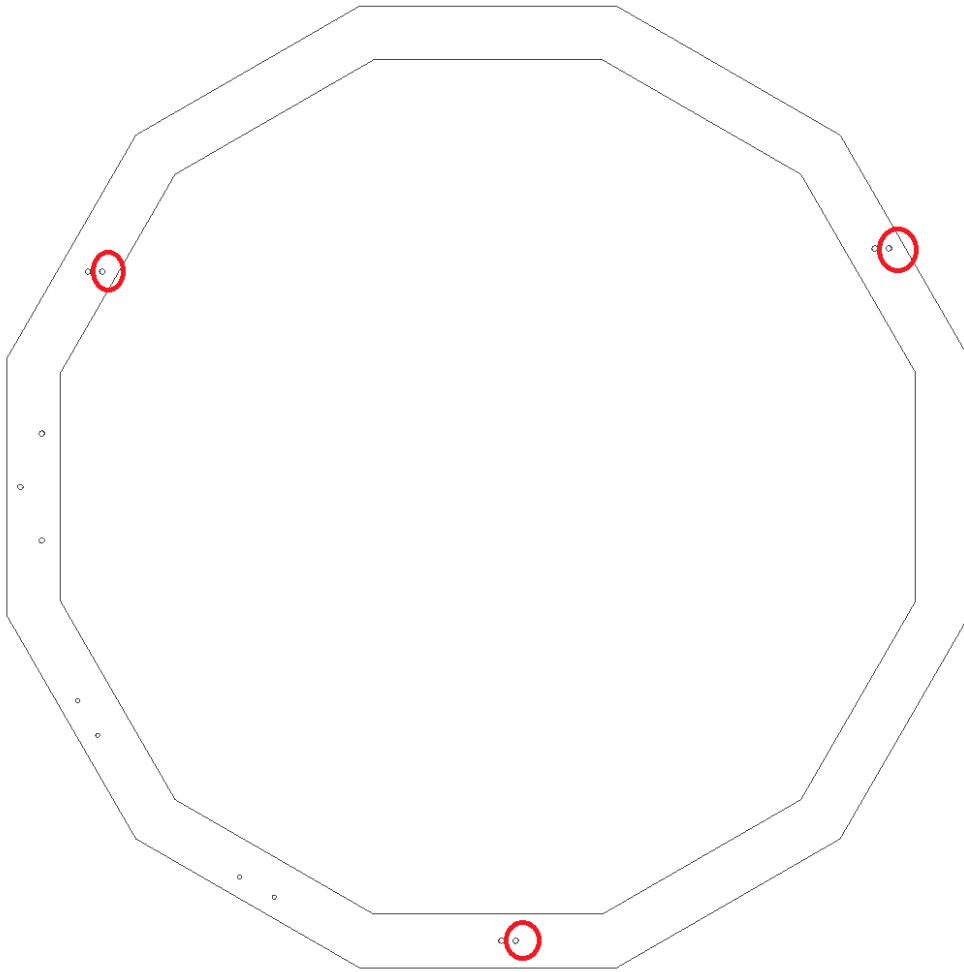
## 2.1.2 Assembly of the Secondary Cage

Please note that most screws needed for the installation are already installed on the parts for easy identification.

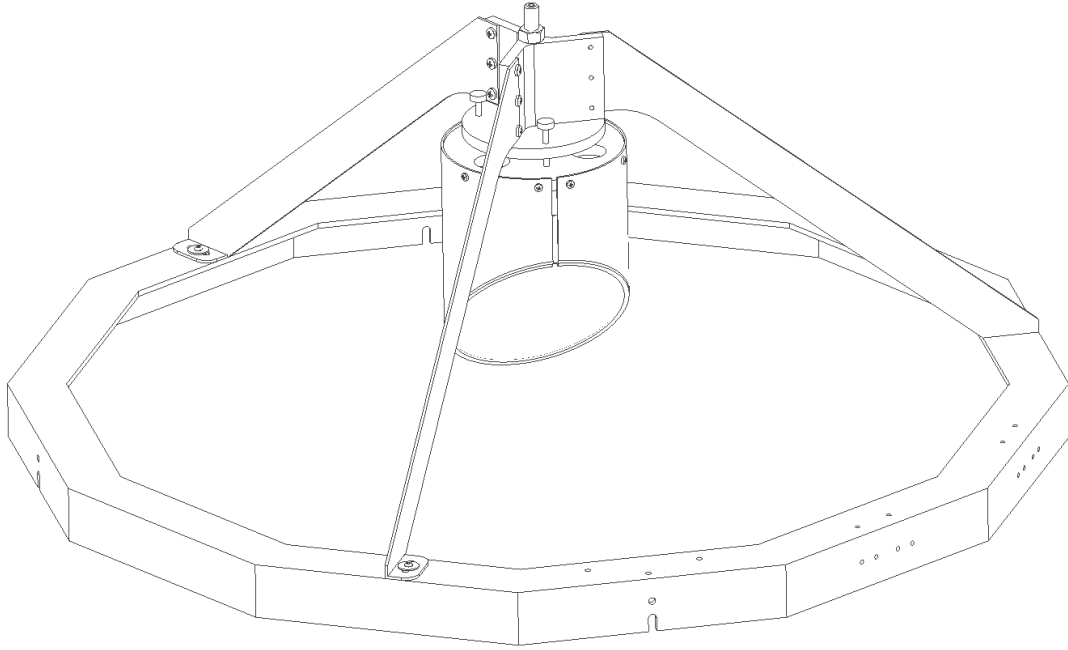
- Attach the three spider wings to the spider holder
- Attach the three spider wings to the upper ring
- Attach the focuser L bracket to the upper ring and tighten the screws
- Attach the focuser to the L bracket and tighten the screws
- Attach the secondary holder with the secondary mirror (installed and cured)
- Roughly adjust the center bolt and the orientation of the secondary holder until the secondary mirror is centered by being viewed from the focuser draw tube
- Adjust and tighten the three collimation screws.



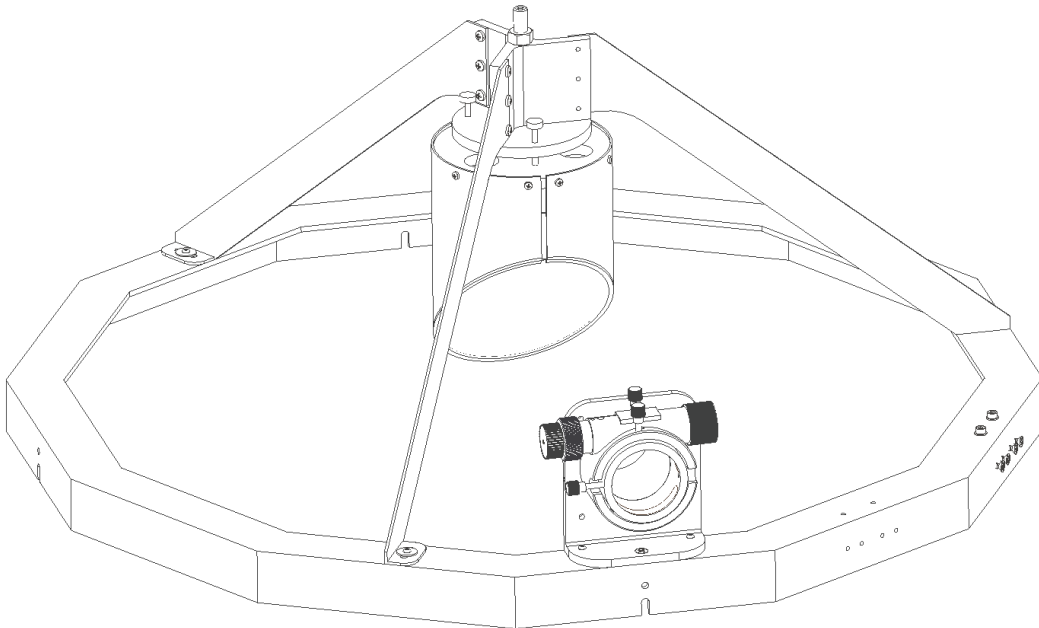
**Figure 5: Attach the three spider wings to the central spider hub**



**Figure 6: Attach the three spider wings to the holes circled in red to offset the secondary mirror**



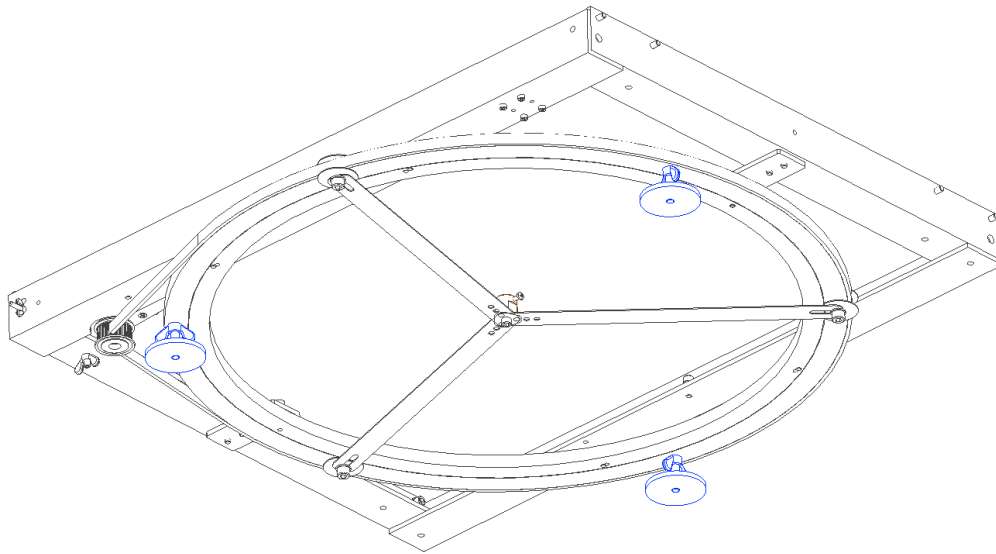
**Figure 7: Attach the three spider wings to the upper ring**



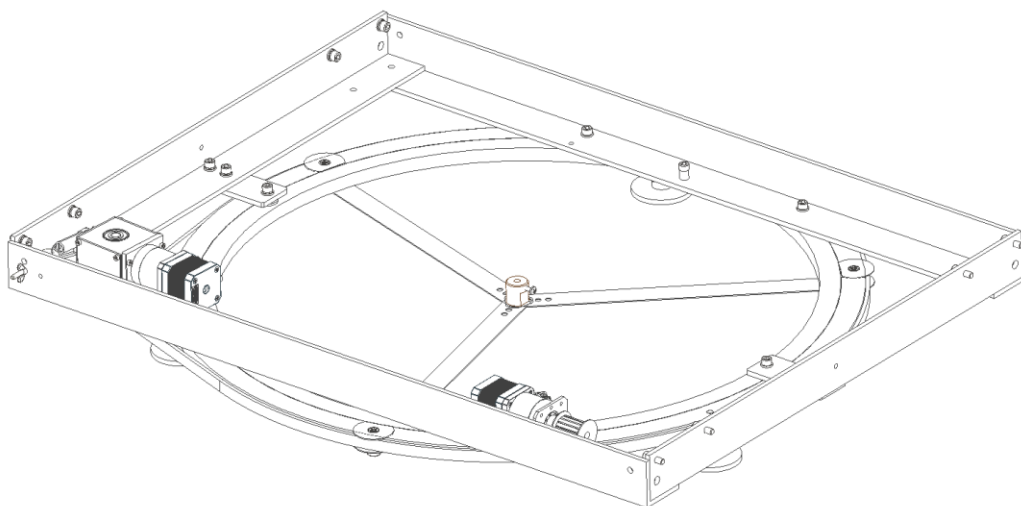
**Figure 8: Attach the focuser to the upper ring**

## 2.2 Assembly of the Dobsonian Rocker

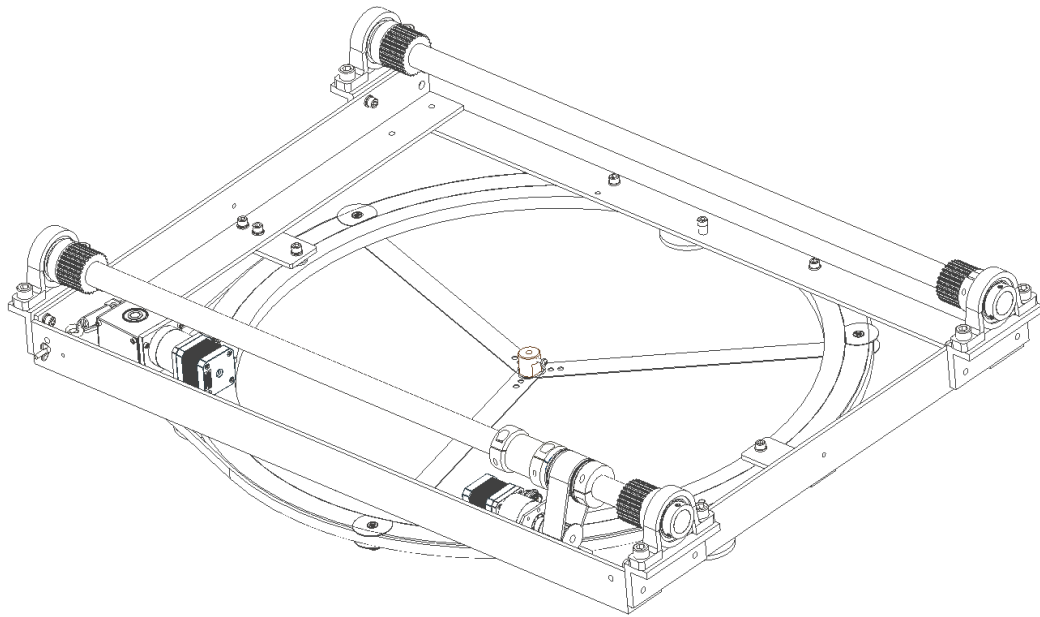
Install the 3 scope feet first, and level the ground board:



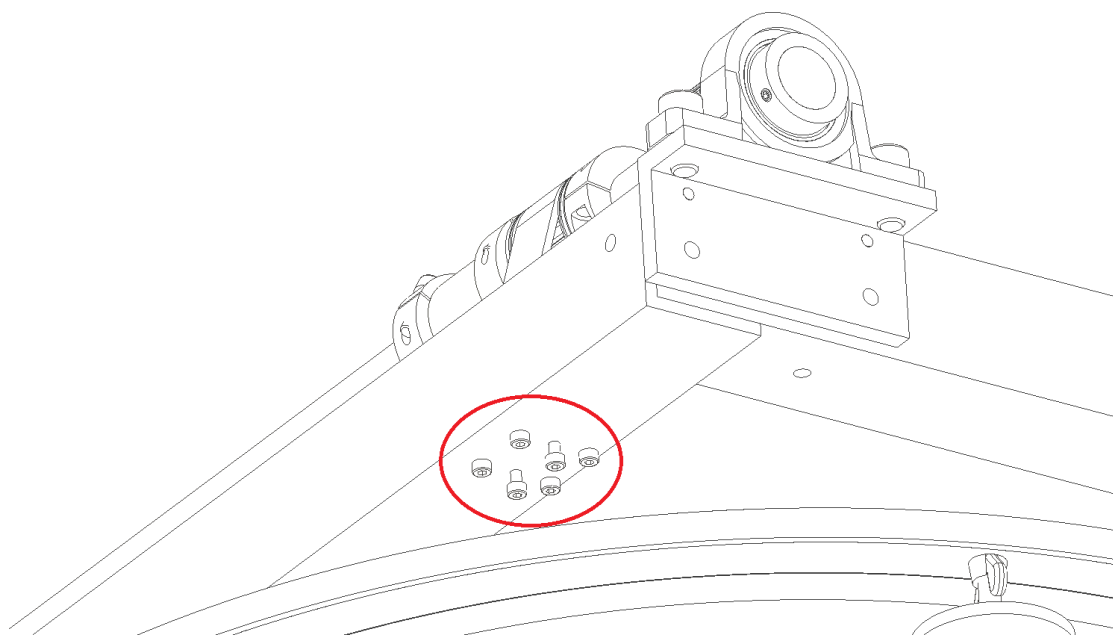
Please note that the UL24g drive system is not only fully assembled but also thoroughly tested before being shipped. You won't need to take any further steps. However, the following assembly instructions are provided here should they be needed.



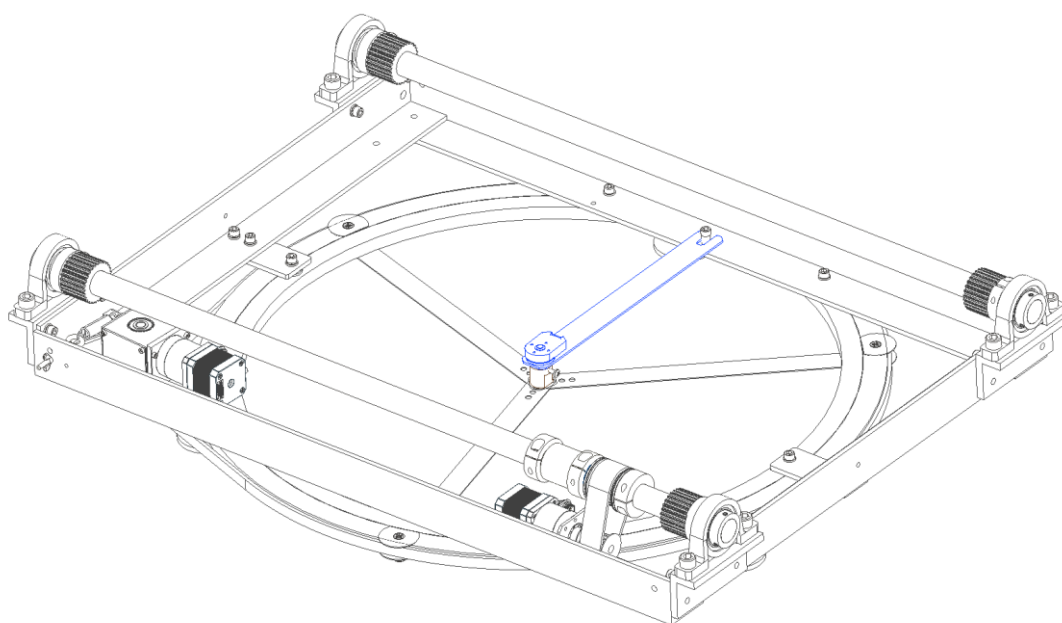
Install the 2 ALT drive shafts on top of the rocker:



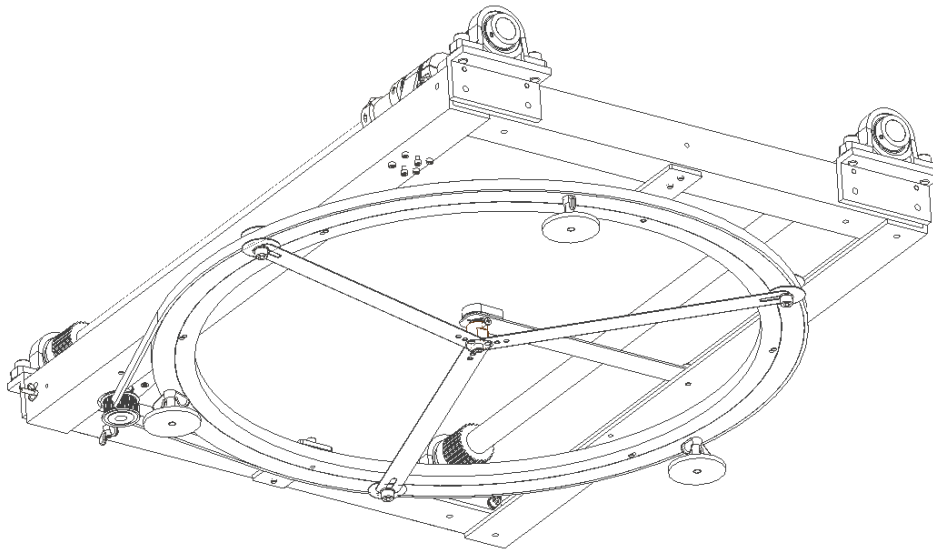
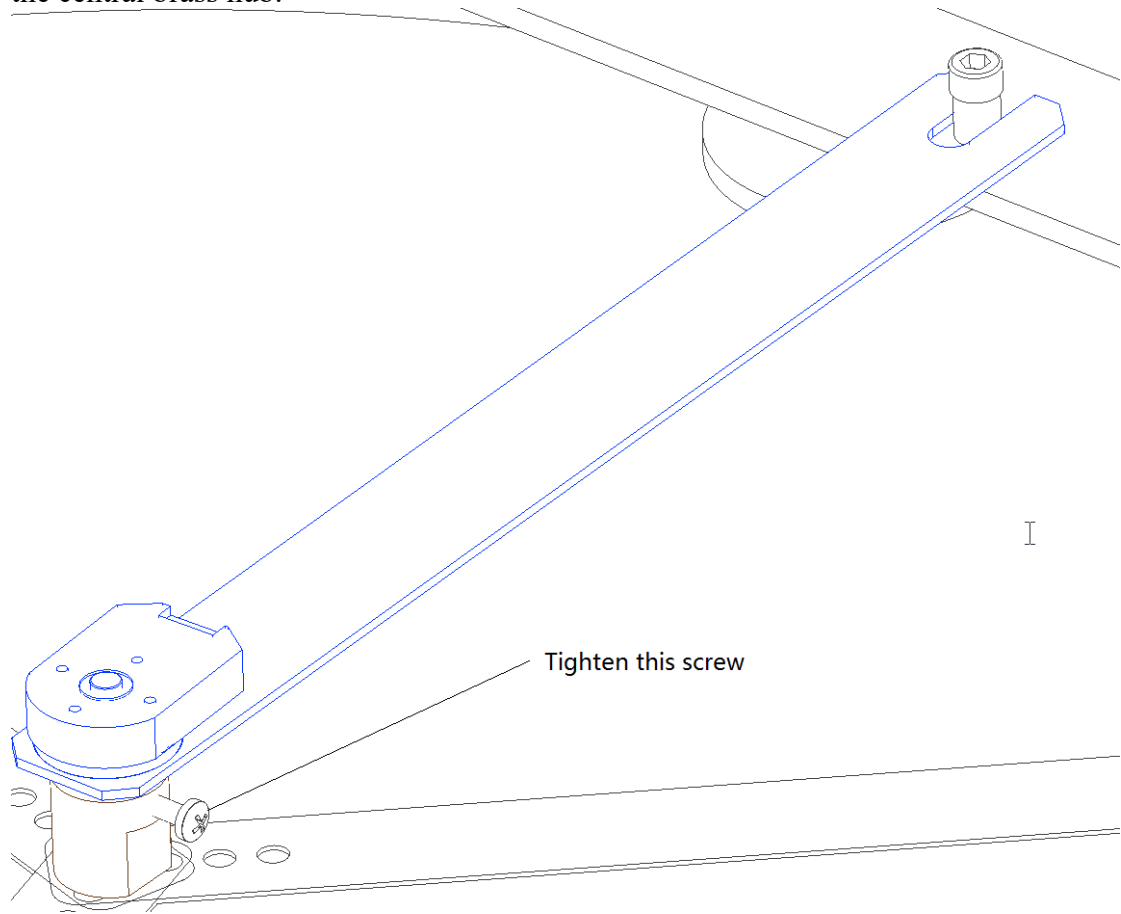
Make sure that the ALT transfer timing belt is tightly fit. The stress of the belt has been adjusted before shipping; however, if needed, you can adjust the belt stress by adjusting the ALT motor assembly installation screws circled in red in the following picture.



Install the AZM Encoder assembly.



Please make sure to tighten the encoder shaft using the provided M4 nylon screw in the central brass hub.

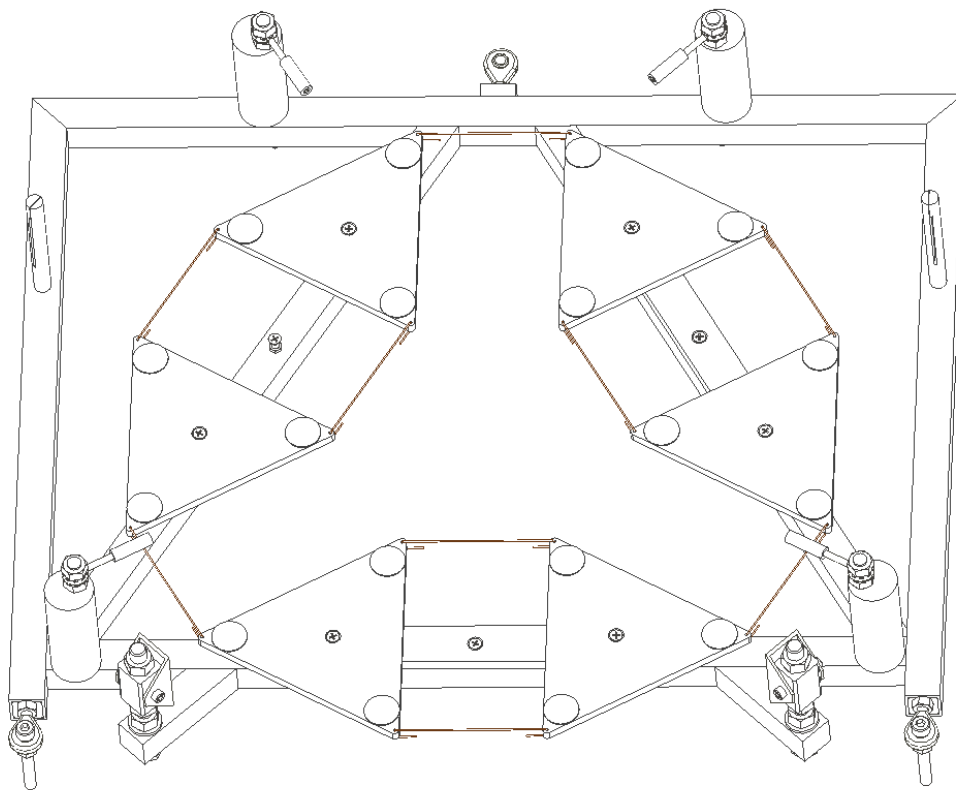


## 2.3 Assembly of the Mirror Box

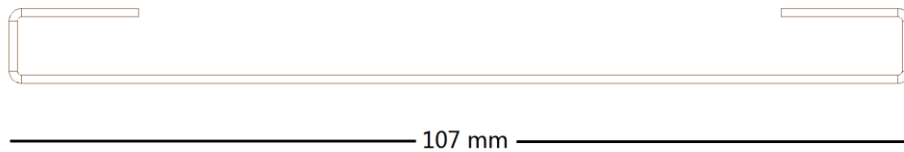
The mirror box is very much assembled already; but you do need to install the ALT bearings and load the primary mirror into the mirror box.

Before installing the primary mirror, you need to perform the following tasks:

- Attach the 18 adhesive scratch protectors to the six support triangles - three per triangle, one at each corner where the mirror rests - so the mirror glass never touches bare metal
- Attach the 9 brass wires to regulate the support bars and angles



Bend 9 brass wire to the following shape, with the center portion to be about 107 mm (a bit longer is OK, but all nine should be the same length as much as possible).



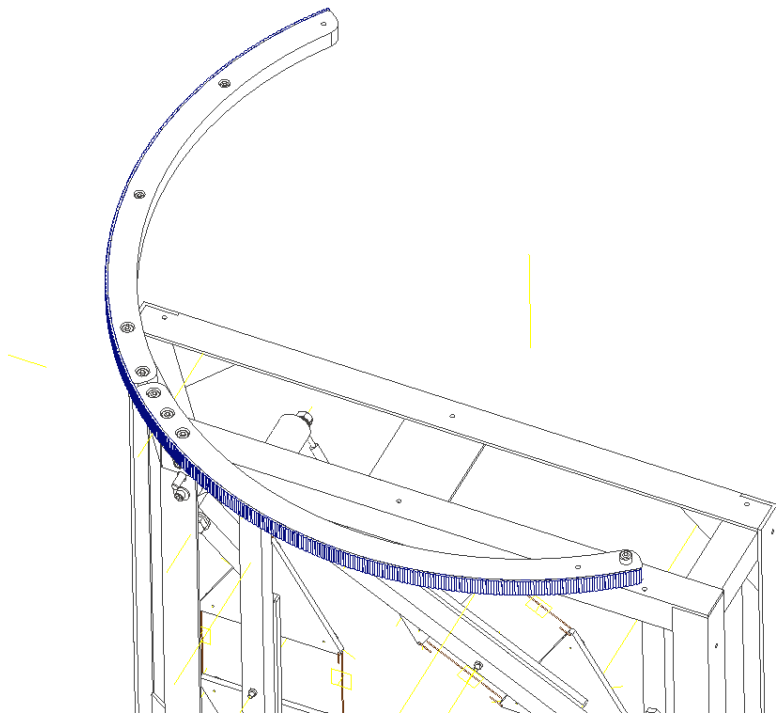
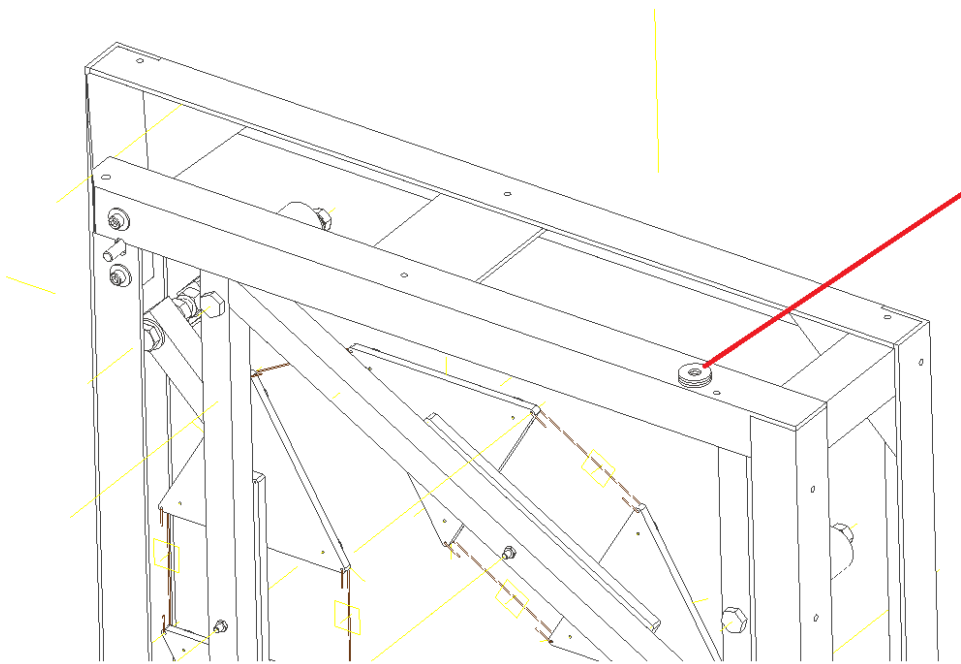
Insert the brass wires into the small holes on the support bars, and then bend the head portions to lock the brass wires in the position.

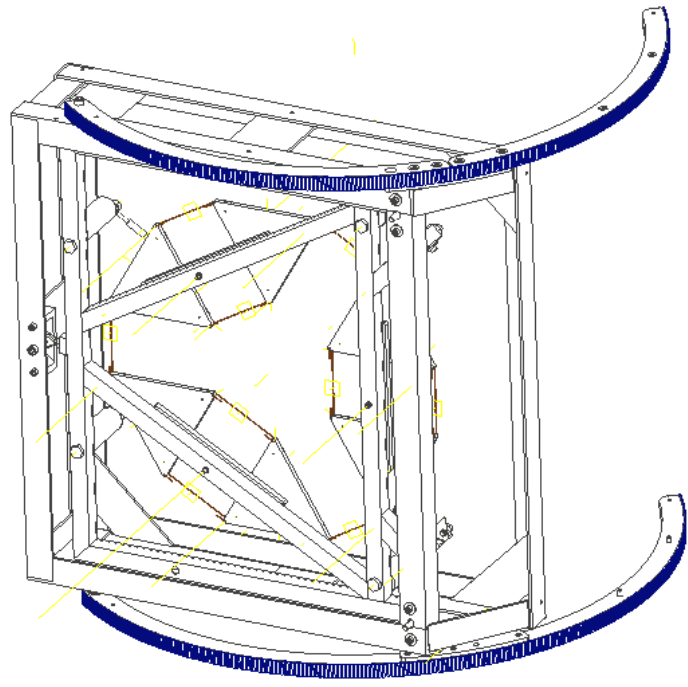
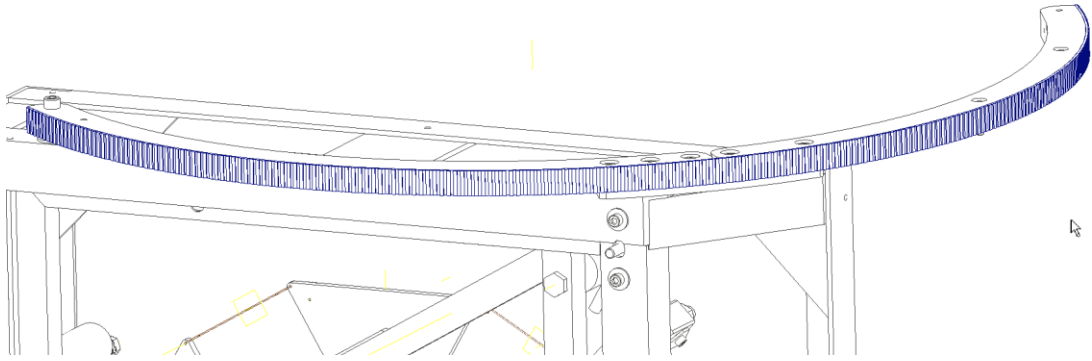
The primary mirror is shipped in its own box. Once the primary mirror is installed in the mirror box, there will be no need to remove the mirror until cleaning is necessary. However, for shipping, long distance transportation, and the long time storage, the primary mirror should be packed tightly in its original package.

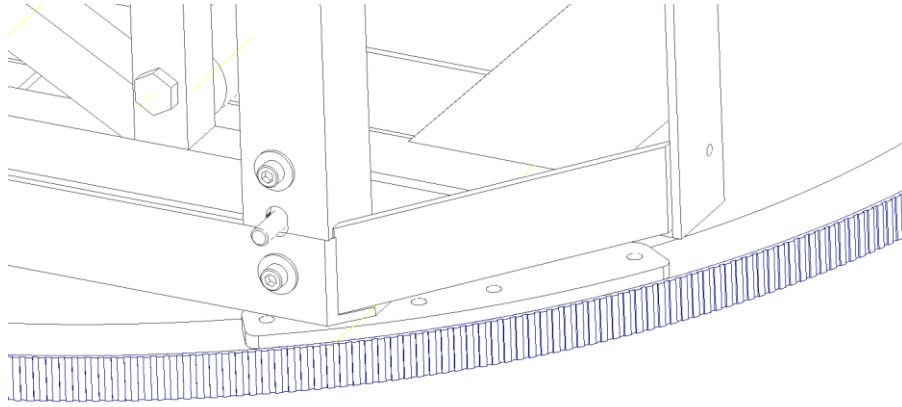
### 2.3.1 Install the ALT bearings.

Each ALT (altitude) bearing is made of two curved pieces - **a lower portion and a top portion** - that form one complete arc; on the UL24G they are **shipped already connected**. **Only the lower portion bolts to the mirror box**: it is the end with the **two countersunk (stepped) holes** that match the mounting holes on the mirror box.

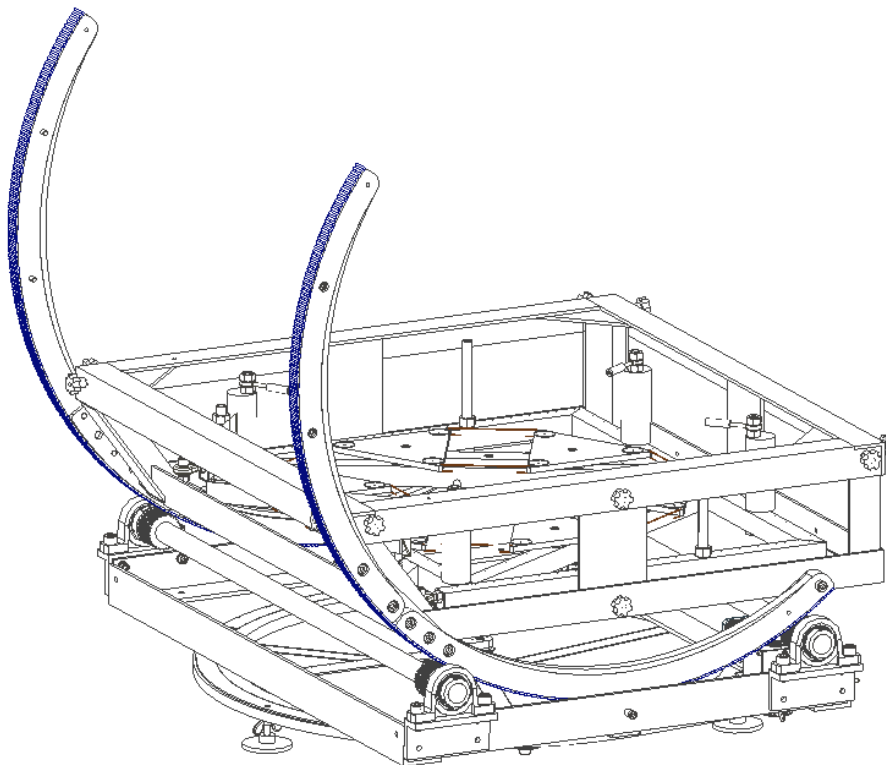
1. Lay the mirror box on its side on a padded surface.
2. Bolt the lower portion to that side of the mirror box, driving the screws through its two countersunk holes into the matching holes in the box. The provided spacer is needed on one of these holes.
3. Turn the mirror box over and repeat for the second ALT bearing on the other side.

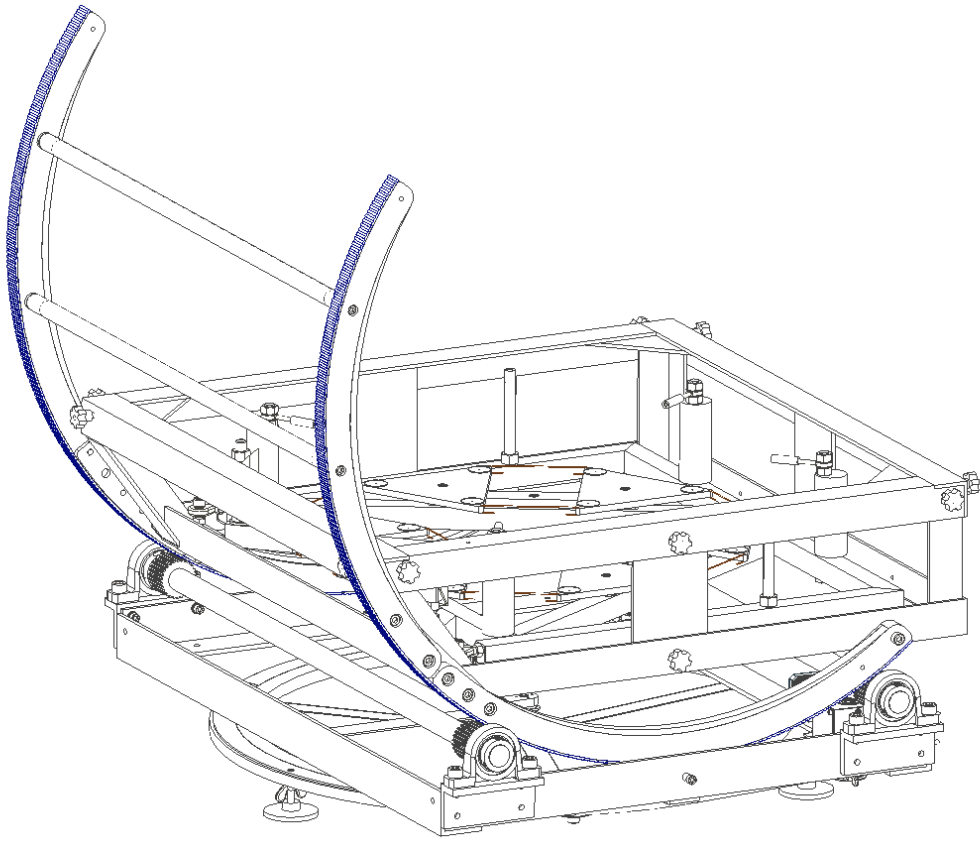




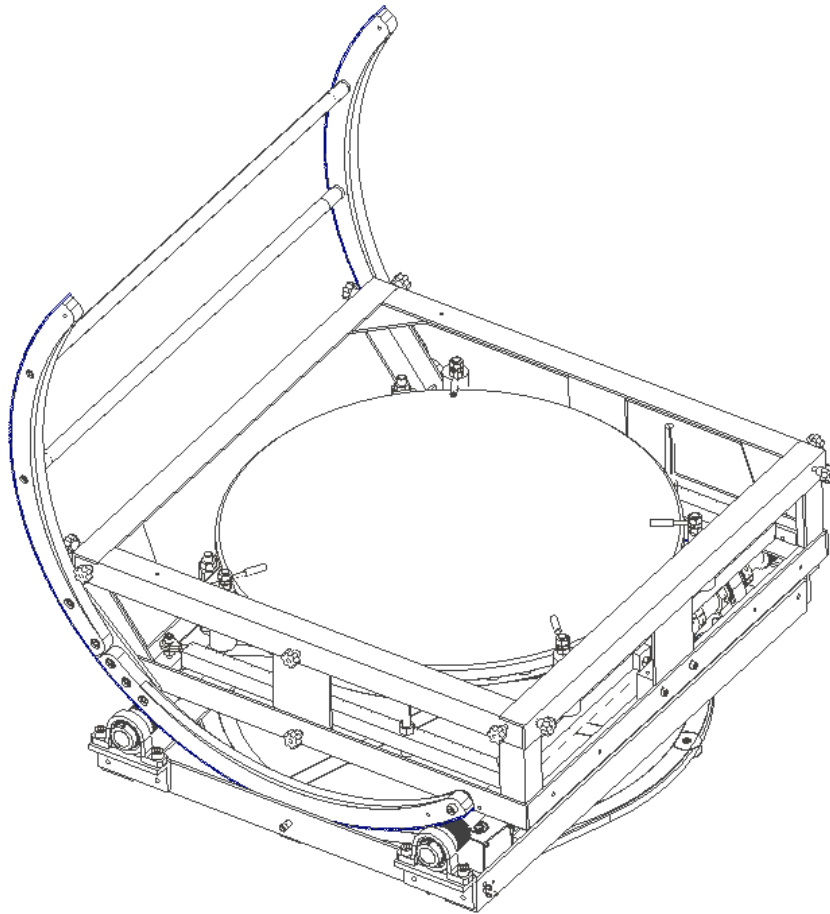


Place the mirror box carefully onto the Rocker/Ground board. The two front ALT bearing cross bars (colored in blue below) are included for extra reinforcement of the ALT bearing. Using them is optional - most users do not need them. If you want the additional support, install them as below:





## 2.3.2 Install the Primary Mirror

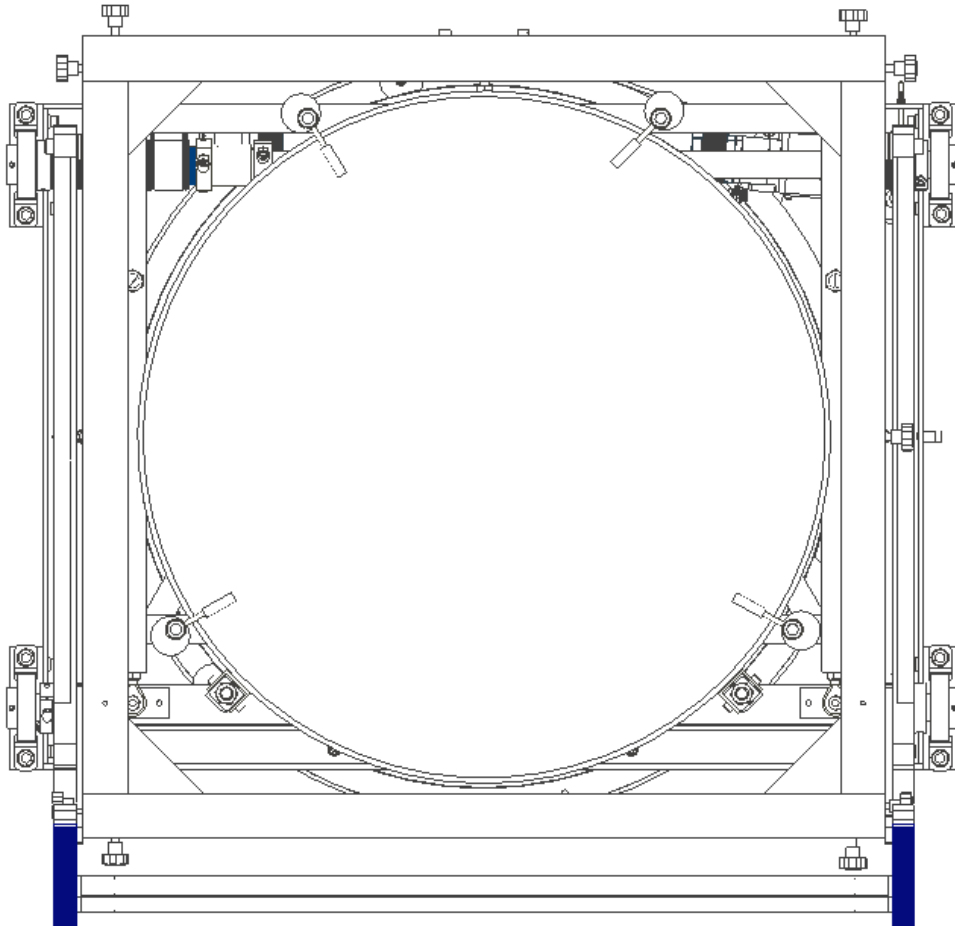


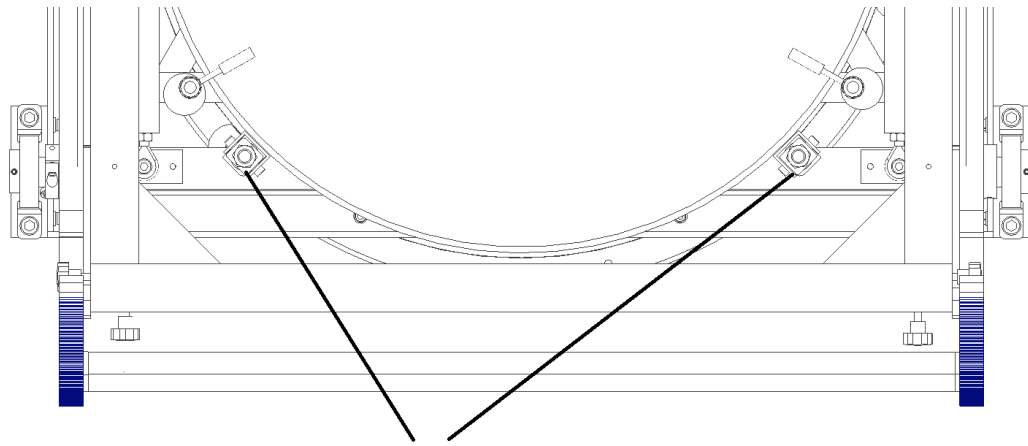
Rotate the four eccentric side pins to make room for the primary mirror. Loosen the locknuts on the top of the mirror clips and turn them aside.

Make sure the mirror box is locked in place with one or two nylon strip/belt to the rocker. Also make sure that all three mirror support bars/triangles are evenly placed in

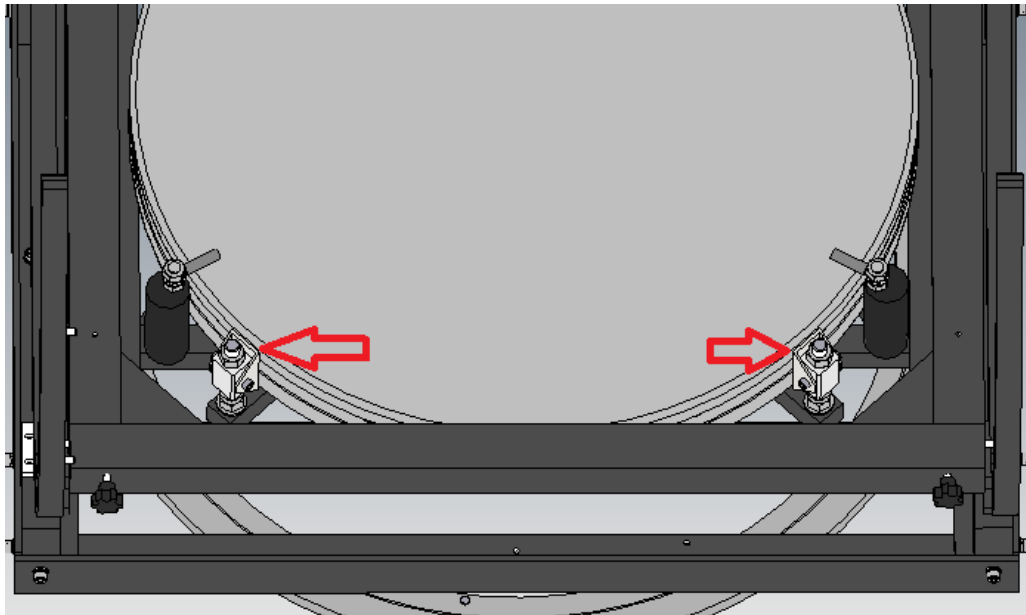
the cell. Pick up the mirror and place it into the mirror cell. Check that the mirror is centered and wiggles it a bit to ensure that the cell parts are moving freely and adjusted to the float of the mirror.

Viewed from the above, the primary mirror should be well centered in the mirror box:

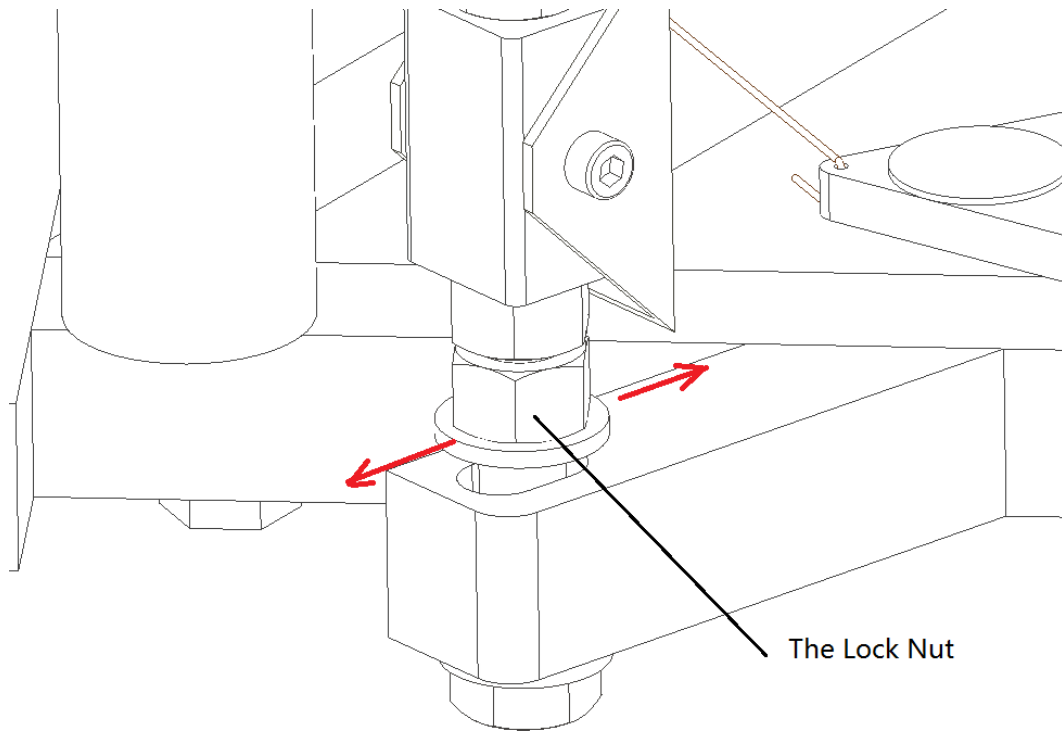




The Lateral Supports

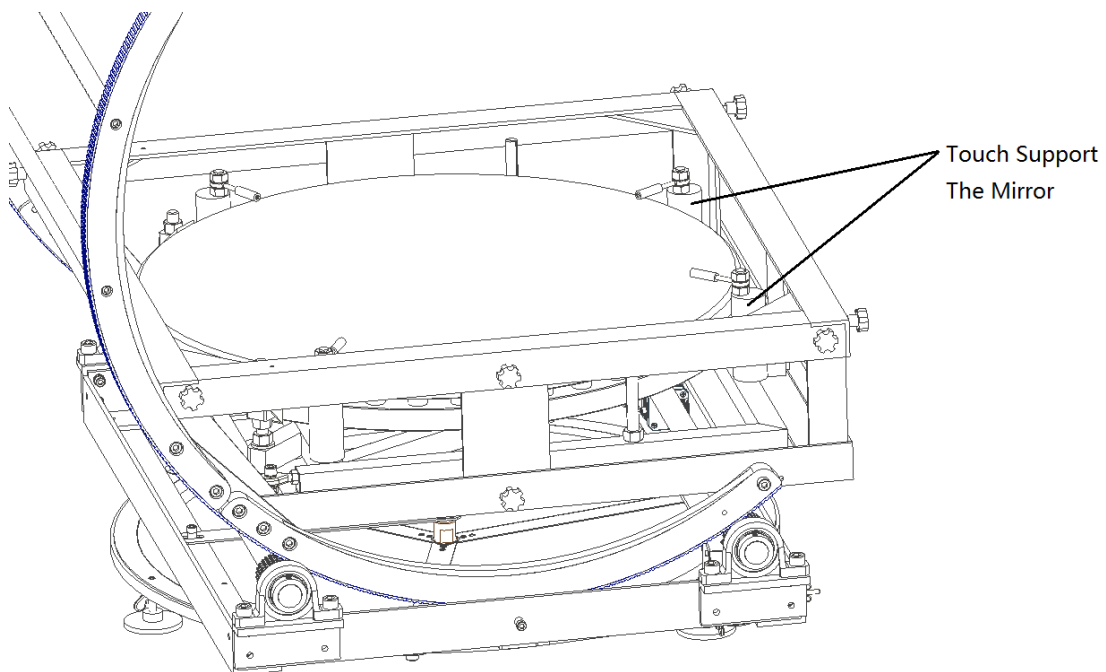


Pivot support

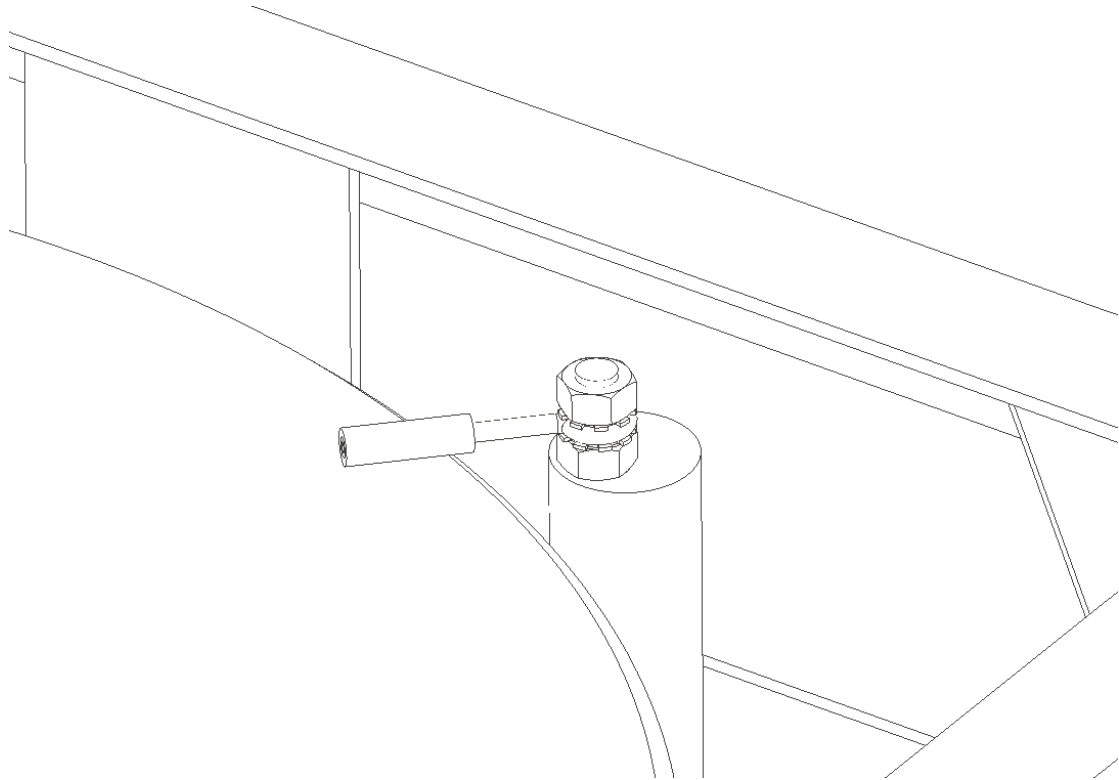


You can loosen the lock nut to adjust both lateral support's position as shown in the above picture to adjust the primary mirror's position.

The bottom side pins (the two side pins next to the pivot support) should not contact the mirror during observation. **However, the top two side pins should lightly touch/support the mirror.**

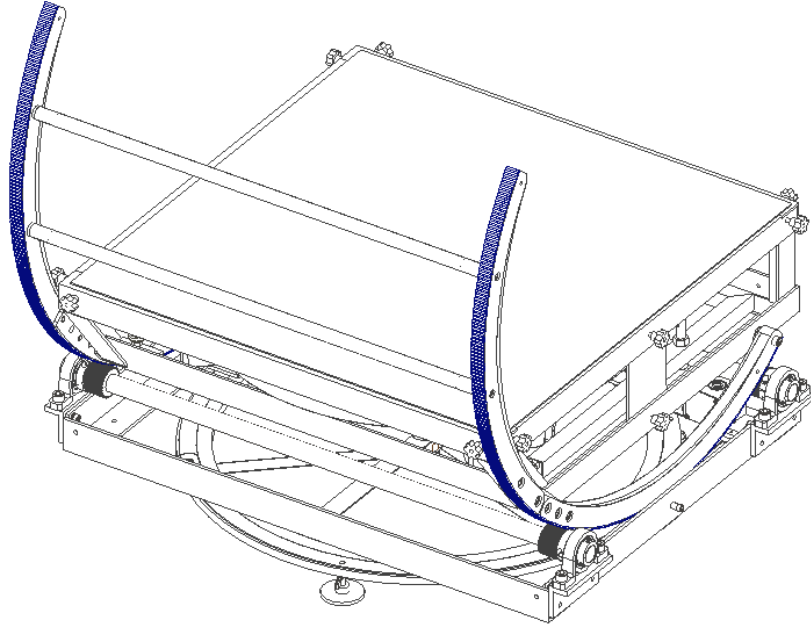


The mirror protecting clips should not contact the mirror at all. Keep the clips about 3-6mm above the mirror surface and tighten the top lock nuts.



Mirror Collimation Bolts

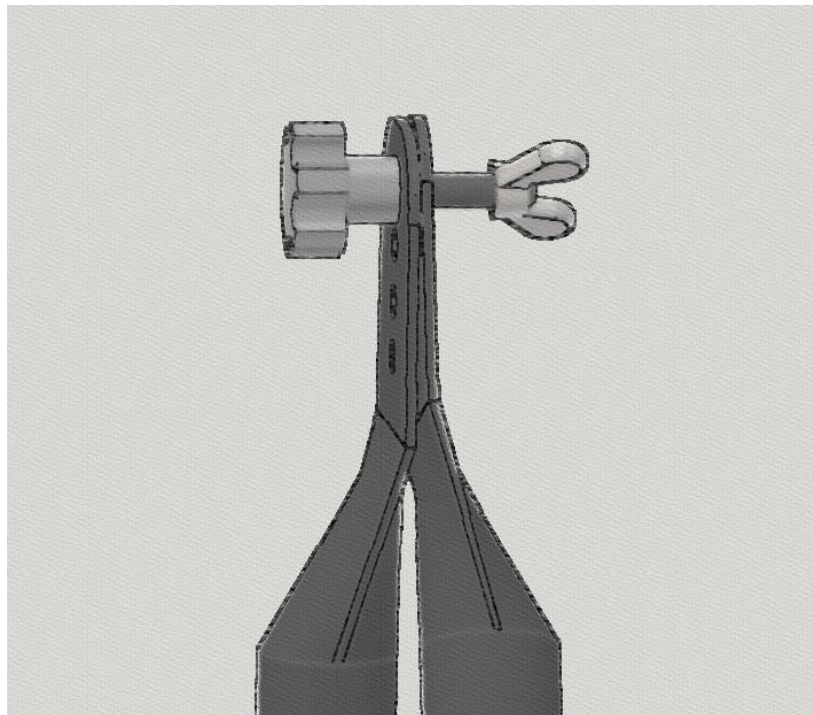
**Once the mirror is installed, you should cover the mirror box to protect the mirror from any accident.**

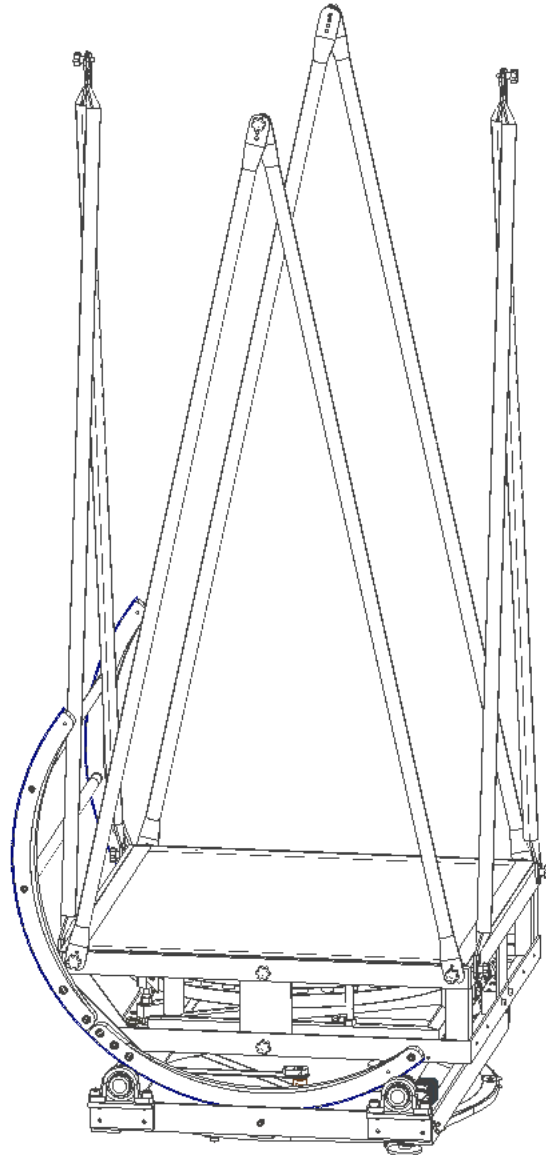


## 2.4 Install the Truss Tubes and Secondary Cage

### 2.4.1 Installation of the Truss Tubes

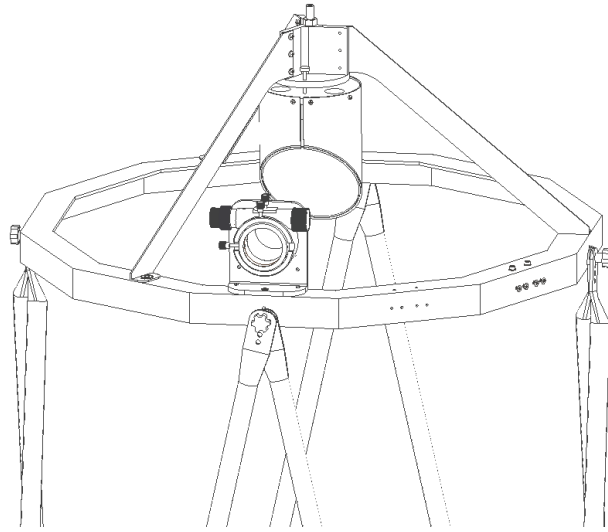
1. **Asymmetric Truss Tube Ends:** The ends of the truss tubes are asymmetrically shaped to enable connection in opposite orientations. This design helps to avoid interference between the tubes during assembly.
2. **Primary Mirror Protection:** Ensure that the primary mirror is fully enclosed and protected. A mirror box cover is recommended for this purpose.
3. **Truss Tube Connection:** Attach each pair of truss tubes using an M6 knob screw, and secure it with an M6 wing nut. This connection should be made on the side of the tube that has multiple holes. These multiple holes allow for adjustments in the overall tube assembly length, which is necessary to accommodate slight variations in the primary mirror's focal length. Typically, the second hole from the top is the recommended starting point for this connection.
4. **Attaching Truss Tubes to Mirror Box:** Finally, connect each pair of truss tubes to the mirror box using a M6 knob screw.



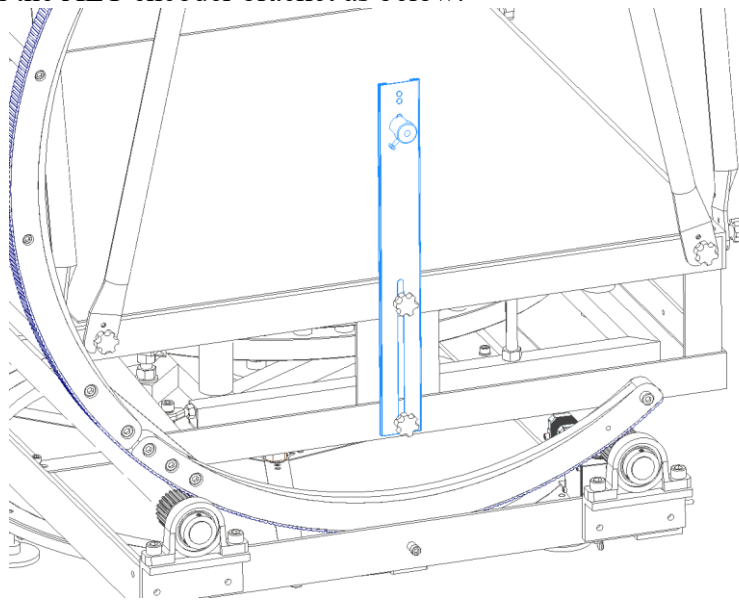


## 2.4.2 Installation of the Secondary Mirror Cage

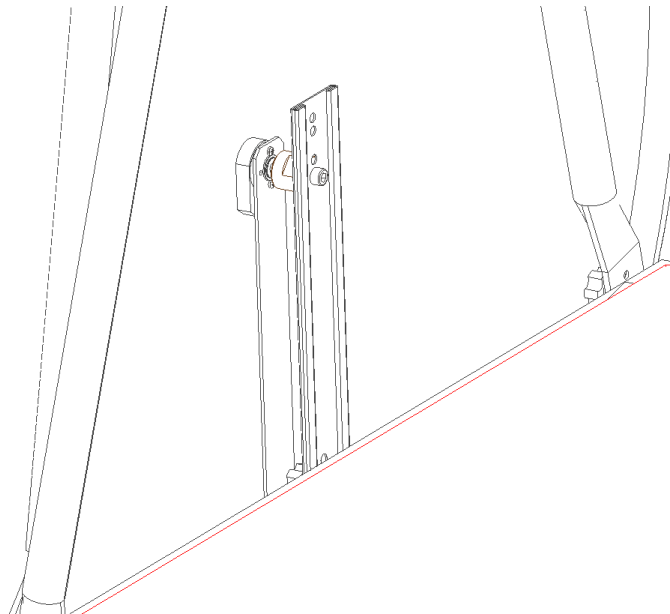
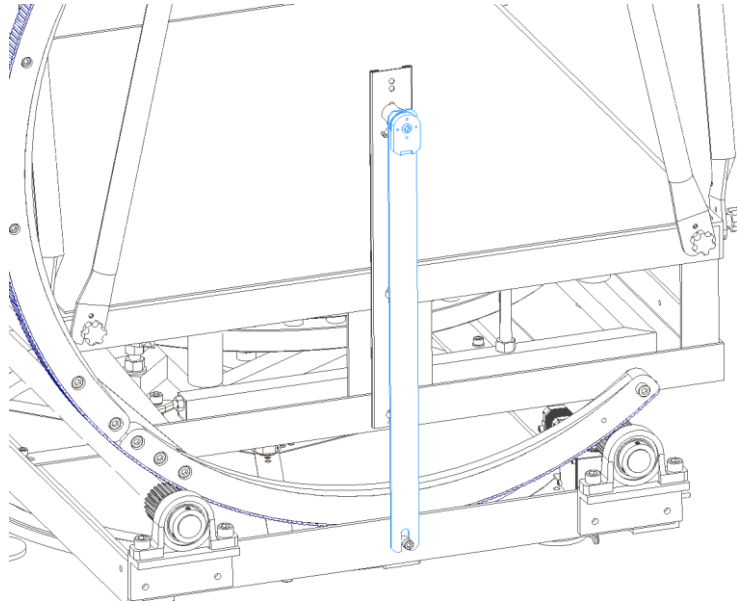
Make sure that the primary mirror is fully protected with a mirror box cover. Then carefully install the upper ring on to the top of the truss tubes. Tighten all the top and bottom truss tubes locking screws once the upper ring is positioned correctly.



Then install the ALT encoder bracket as below:



Then install the ALT encoder assembly as below:



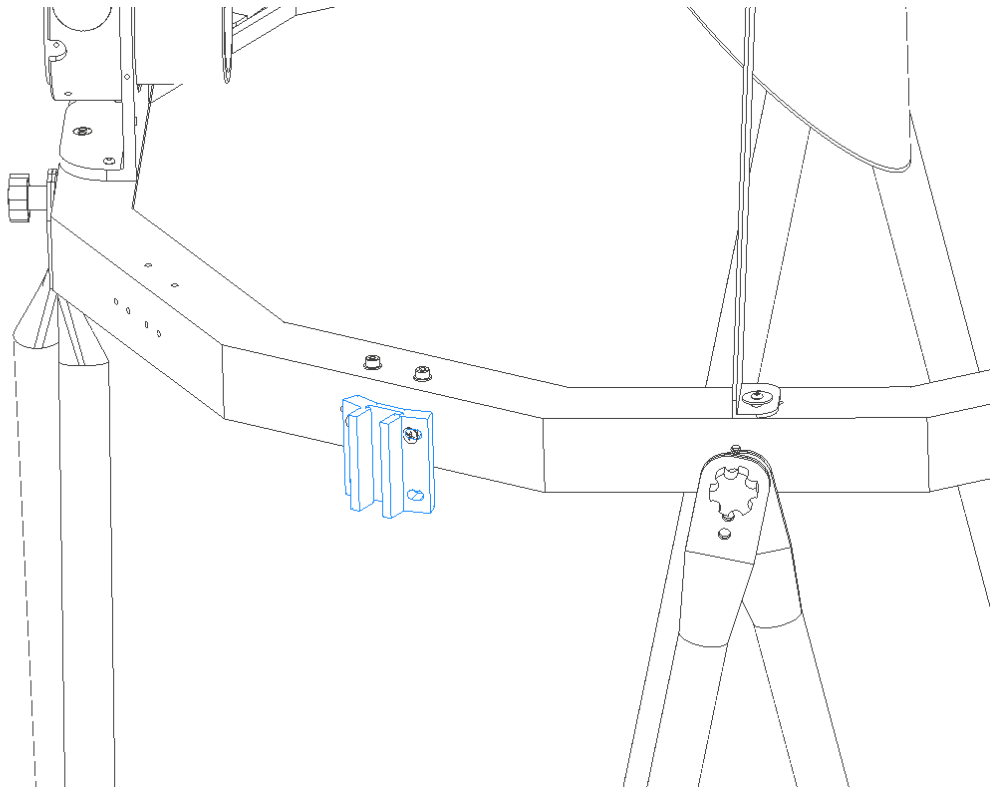
To ensure that the ALT encoder is accurately centered on the virtual ALT bearing axis, you must adjust the position of the ALT encoder bracket. Follow these steps to verify perfect centering of the ALT encoder:

1. Position the telescope so it points towards the zenith (directly upwards), and then adjust it to 45 degrees and 90 degrees orientations.

2. Observe the pivoting screw at the bottom of the ALT encoder assembly. When the ALT encoder is correctly centered, this screw should maintain the same relative position to the ALT encoder assembly throughout the adjustments.
3. If the ALT encoder assembly shifts up and down as you move the telescope, you need to adjust the encoder support bracket. Move the bracket up or down until the movement of the telescope no longer causes the ALT encoder assembly to shift.

### 2.4.3 Installation of the Optional Finder Scope

Use 2 provided (hexagon or cross) socket sunk head screws to mount the finder scope base to the upper ring.



## 3. Balance the scope

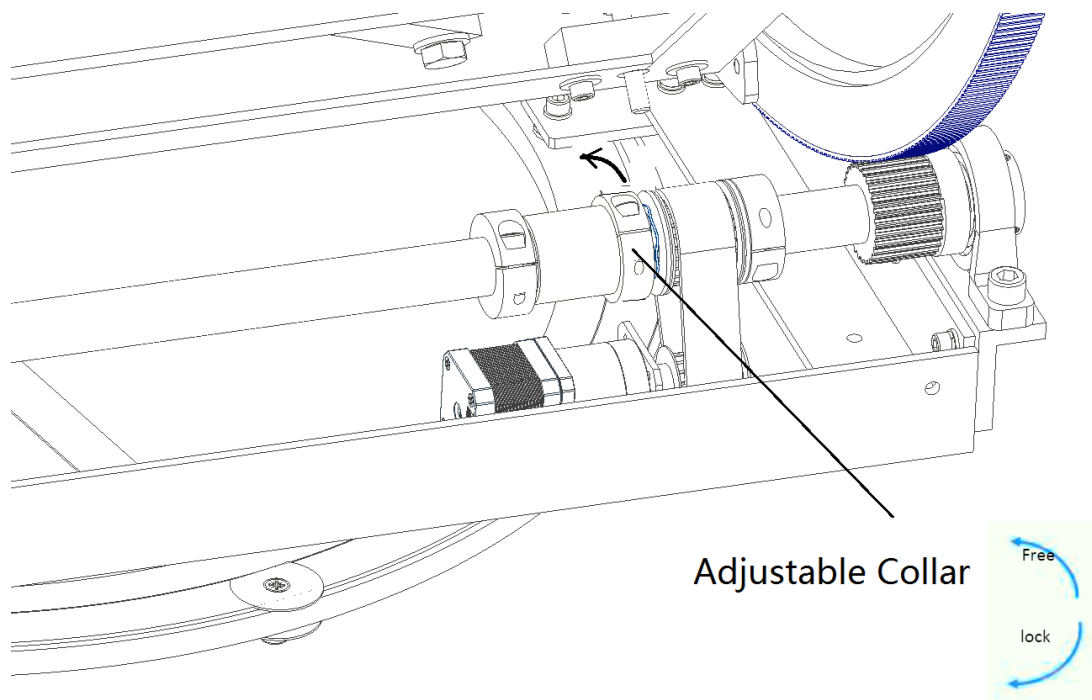
To properly use the GoTo feature, it's essential to first balance the telescope. Follow these steps to balance the scope and enable manual mode in the ALT axis:

1. **Unlatch the ALT Drive:** Start by unlocking the ALT drive to allow manual movement in the ALT axis. This is done by rotating the adjustable collar in the

direction shown in the accompanying picture. This action unlatches the ALT drive and puts the scope in manual mode for the ALT axis.

2. **Manual Adjustment:** With the scope in manual mode, manually move the scope up and down. A well-balanced scope will remain stationary at any position you leave it. If the scope does not stay put, you will need to adjust its balance by adding counterweights.
3. **Adding Counterweights:**
  - If the scope tends to move downward on its own, it is top-heavy. In this case, add counterweights to the bottom, specifically on the mirror box.
  - Conversely, if it doesn't stay in position or feels bottom-heavy, add counterweights to the top, on the upper ring. Note that the counterweights are not provided and will need to be sourced separately.
4. **Securing the ALT Drive:** Once the telescope is balanced — meaning it stays in place at any position you set it — proceed to secure the ALT drive system. This is done by firmly rotating the adjustable collar to latch the ALT drive.

These steps ensure that the telescope is well-balanced, which is crucial for accurate positioning and optimal performance of the GoTo system



### 3. Connect the GoTo wirings

- Connect the two motors to the controller (**You must not connect or disconnect the motors when the controller is powered on**)
- Connect the two encoders to the Controller
- Connect 12V-24 VDC (center positive) to the controller

## 4. Collimate the Optics.

### Collimating a Telescope

Collimating a telescope may initially seem daunting, but it quickly becomes a manageable routine with a bit of practice. It's important to regularly check your telescope's collimation, especially after transporting it, to ensure you're getting the best views of the night sky.

#### Preparation:

- During the first three steps of collimation, keep the primary mirror covered.
- Position the telescope approximately 60 degrees above the horizontal plane.
- Ensure collimation remains consistent at various altitudes by securely tightening all nuts and screws along the optical path. This includes:
  - The focuser and its base.
  - The focuser base and upper ring connections.
  - All spider vanes to the spider hub and upper ring.
  - Secondary mirror collimation screws after adjustment.
  - Truss tubes' knob screws.
  - Primary mirror locking screws.

For added collimation stability, especially under heavy loads, mount the focuser directly atop the side truss tubes, despite having two mounting positions for convenience. You may also replace all the truss tubes' knob screws with regular SS304 socket screws, which will add extra stability to the truss structure.

**Step 1:** Center the secondary mirror along the axis of the focuser drawtube.

For this step, use a simple collimation cap (or sight tube). Insert the cap into the focuser and look through the peephole of the sight tube at the secondary mirror. If you don't have a collimation cap or sight tube, you can approximate by eyeballing from a distance, positioning your eye centered with the drawtube.

The secondary mirror should appear round and be exactly centered within the sight tube. If it is, then Step 1 is complete. If not, adjustments might be needed for either the secondary holder, the focuser, or both.

Begin by checking and adjusting the secondary holder. If the error is vertically up or down, adjust the central bolt that connects the holder to the spider hub.

If the discrepancy is to either side of the focuser (perpendicular to the optical axis), examine if the secondary holder is centered within the upper ring. If it's off-center, adjust the spider wings until it's centered.

**Step 2:** Adjust the tilt of the secondary mirror to direct the focuser's axis toward the center of the primary mirror. To start, remove the cover from the primary mirror.

For this step, you'll need a laser collimator. Insert the laser collimator into the focuser tube. Adjust the three secondary mirror collimation screws until the laser beam is centered on the primary mirror's center spot.

A slight misalignment in the secondary mirror is typically not problematic. As long as the pointing error remains within 1 or 2 percent of the main mirror's diameter, it won't cause any noticeable differences.

**Step 3:** This step is crucial. Here, you'll adjust the tilt of the primary mirror to ensure the returning laser beam centers on the centre of the laser collimator.

Manipulate the three primary collimation screws and their adjacent locking screws to align the laser's returning beam with the collimator's faceplate.



**Figure 10:**The primary mirror is not yet collimated.



**Figure 9:**The primary mirror is collimated by laser collimator.

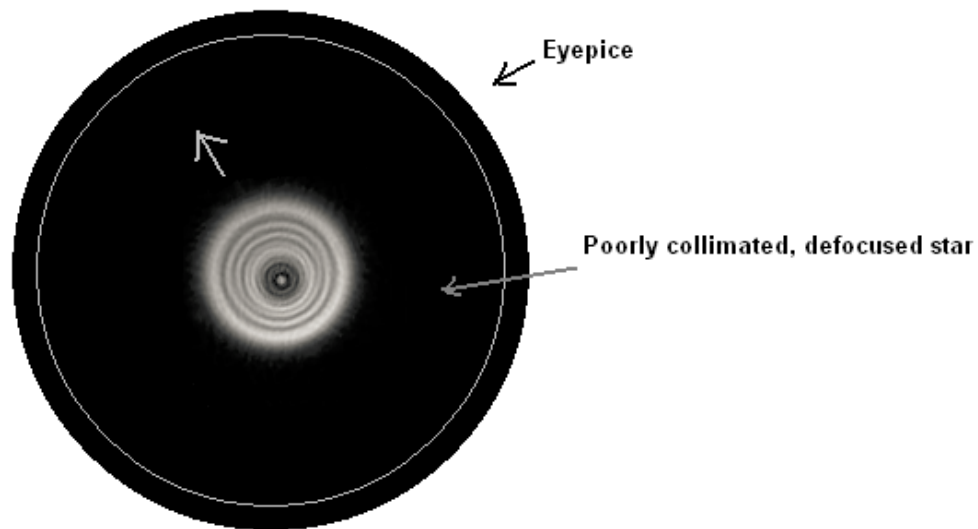
#### **Step 4: Star-Testing Your Collimation**

To accurately collimate your telescope, the star test is an effective method. Here's how to do it:

1. **Selecting a Star:** Choose a moderately bright star for this test.
2. **Aiming the Telescope:** Point your telescope at the selected star.
3. **Defocusing the Star:** Slowly defocus the telescope until the star forms a distinct 'donut' shape. This shape is a ring of light with a central dark spot, which is the shadow of the secondary mirror.
4. **Analyzing the Donut Shape:** Observe the donut. A perfectly collimated telescope will show a centered dark spot. If the central spot is off-center, it indicates misalignment.
5. **Adjusting the Primary Mirror:** If the donut's hole is not centered, gently adjust the primary mirror's collimation screws. Make small adjustments: tighten one screw while slightly loosening the opposite screw to maintain even pressure. Aim to move the defocused star image towards the thicker side of the donut.
6. **Re-centering the Star:** After each adjustment, re-center the star in your telescope's field of view by re-aiming the telescope. The position of the star may shift slightly with each collimation adjustment.
7. **Repeating the Process:** Continue this process - adjusting, re-centering, and observing the defocused star - until the donut shape appears symmetrical with the central hole perfectly centered.

8. **Final Symmetry Check:** Once the donut appears symmetrical, fine-tune your focus to check the concentric rings around the star. Proper collimation is indicated by centered and symmetrical rings.

Remember, atmospheric conditions can affect the appearance of the star's image. Conduct this test on a night with stable and clear atmospheric conditions for the best results.



It's advisable to carry out this procedure at the onset of each observing session. Additionally, you should check the collimation sporadically throughout the night. This is crucial because factors like temperature variations or routine handling could cause shifts in your telescope's components, potentially affecting the collimation.

## 5. Care and Maintenance

### 5.1 Mirror Storage

Your scope should be stored in a clean, dry, dust-free place, safe from rapid changes in temperature and humidity. Do not store the telescope outdoors, your garage and shed might be OK, but is not recommended. We highly recommended storing the secondary cage, the mirror box with in our optional waterproof Nylon storage bag. Although big enough, make sure do not store the rocker/ground board with the mirrors in the bag for long time; the potential evaporation from the lubricate material used by AZ bearing under high temperature will be harmful to the mirror coating.

## 5.2 Mirror Cleaning

You should not have to clean the mirror often. The best thing you can do to keep your mirror is to prevent it from getting dirty in the first place! A simple air-blow cleaning, using an optical air dust blower is the next best thing you can do.

# 6. Specification

- Optical design : Reflector
- Optical diameter : 609.6mm
- Focal length : ~2012mm
- Focal ratio : ~f/3.3
- The focuser height at zenith:~1955mm
- Optics type : Parabolic
- Eyepieces: Not included
- Optical quality : Diffraction limited++ (Strehl 0.95+ for the primary mirror)
- Finder scope : Not included
- Focuser : 2" dual-speed linear bearing Crayford
- Secondary mirror obstruction : 127 mm
- Secondary mirror obstruction by diameter : 20.8%
- Secondary mirror obstruction by area : 4.3%
- Mirror coatings/over-coatings : 96% Enhanced Aluminum coating on
- Tube material : 6063-T6 Aluminum Alloy tubes with black stainless steel knob screws; Aluminum Alloy main structure (OTA and mount) and structure steel mirror cell.
- Length of optical tube : 79 in.
- Weight, optical tube : ~61 kg (With rotator, focuser and Renishaw encoder)
- Weight, fully assembled (with GoTo drive) : ~77kg (~170 lbs.)
- Other features: Sling lateral support and deluxe push-pull brass knob collimation screws

# 6. Limited Warranty

Hubble Optics (Optel Engineering Group Inc.), Seller, warrants to the original purchaser only, that goods sold will be free of material defects in design, materials and workmanship for a period of one year following the date of shipment by Seller to Buyer. Seller will repair or replace, or refund the purchase price as to, goods that do

not conform to the foregoing warranty, provided the cause of the nonconformity does not arise from or relate to modification, misuse, or abuse by the customer, and provided a warranty claim, stating in writing and with reasonable particularity the claimed nonconformity, and the goods, are delivered to Seller within the one year period. Repair or replacement of the product or refund of the purchase price, at Seller's sole option, shall be the Buyer's exclusive remedies. Seller shall not be responsible for any indirect, special or consequential damages arising from use of the products. This warranty is given in lieu of any other warranties, express or implied, including of performance, merchantability, fitness for particular purpose, or arising from course of dealing or usage of trade. Goods subject to this warranty must be shipped postage pre-paid by Buyer to the Seller. Some states do not allow the exclusion or limitation of incidental or consequential damages, so the above limitations may not apply to you. This warranty gives you specific legal rights, and you may also have other rights, which vary from state to state.

## **7. Technical Support**

Hubble Optics (Optel Engineering Group Inc.) will provide the support for the basic operations outlined in this document by email. You will receive a response, generally within 24 hours.