

Hubble Optics Ultra Light UL20 Dobsonian instruction manual

REV: 06-03-2026

Please read these instructions thoroughly before beginning assembly and subsequent use of the telescope.

| | |
|--|-----------|
| 1. Unpacking | 2 |
| 2. Assembly | 4 |
| 2.1 Install the Secondary Mirror | 4 |
| 2.1.1 Secondary Mirror Initial Assembly | 4 |
| 2.1.2 Assembly of the Secondary Cage | 6 |
| 2.2 Assembly of the Dobsonian Rocker | 9 |
| 2.3 Assembly of the Mirror Box | 10 |
| 2.3.1 Center Spot The Primary Mirror | 13 |
| 2.3.2 Install the ALT Bearings..... | 14 |
| 2.3.3 Secure the Mirror Box to the Rocker | 17 |
| 2.3.4 Install the Primary Mirror | 19 |
| 2.4 Install The Truss Tubes and Secondary Cage..... | 22 |
| 2.4.1 Installation of the Truss Tubes..... | 22 |
| 2.4.2 Installation of the Secondary Mirror Cage..... | 25 |
| 2.4.3 Installation of the Optional Finder Scope | 26 |
| 2.5 Adjust the Sling..... | 26 |
| 3. Collimation: Mandatory Pre-Observation Alignment | 27 |
| 4. Care and Maintenance | 31 |
| 4.1 ALT Bearing Surface Maintenance | 31 |
| 4.2 Scope Storage..... | 31 |
| 4.3 Mirror Cleaning | 32 |
| 5. Specification | 32 |
| 6. Limited Warranty | 33 |
| 7. Technical Support | 33 |

WARNING: Never look at the sun with your telescope without a professionally made solar filter. Permanent eye damage or blindness could result. Eye damage is often painless, so there is no warning until it is too late. Children should not be allowed to handle the telescope. Avoid using the type of solar filter that screws into an eyepiece. They are susceptible to cracking under the intense heat that builds up near the focus point, and could cause severe retinal damage. Use only the

type of solar filter that covers the front of the telescope. Also, be sure to leave the cover caps on the finder scope when solar observing. Remove the finder scope altogether when viewing the sun.

1.Unpacking

The UL20 telescope is packed in 4 shipping boxes, as described below. We recommend keeping the original packaging for the future usage.

Make sure all the parts in the Parts List are present. Be sure to check all boxes carefully, as some parts are very small. If anything appears to be missing or broken, immediately email Hubble Optics for assistance.

Box #1: the Primary Mirror

Box #2: the Rocker/Ground board/Upper Cage

Box #3: Mirror Box

Box #4: Truss Tubes

| Quantity | Description |
|-----------------|--|
| 1 | Secondary mirror |
| 1 | 2" 10:1 dual speed focuser |
| 3 | Scope feet |
| 4 | M6 knob screws (25mm long) with wing nuts for the truss tube and upper ring connection |
| 8 | M6 knob screws for the truss tube and mirror box connection |
| 4 | M6 knob screws for the ALT bearing reinforcement cross bars |
| 1 | Velcro tape to hold the sling |
| 9 | Brass wire to evenly separate cell support bars |
| 1 | Nylon sling belt |
| 18 | Mirror Cell Support Pad |

Options

| | |
|---|--|
| 1 | 9 x 50 finder scope and bracket (optional) |
| 1 | Shroud (optional) |
| 1 | Truss Tube Carry Bag (optional) |
| 1 | 5-star artificial star (optional) |
| 1 | Mirror Box Cover (optional) |

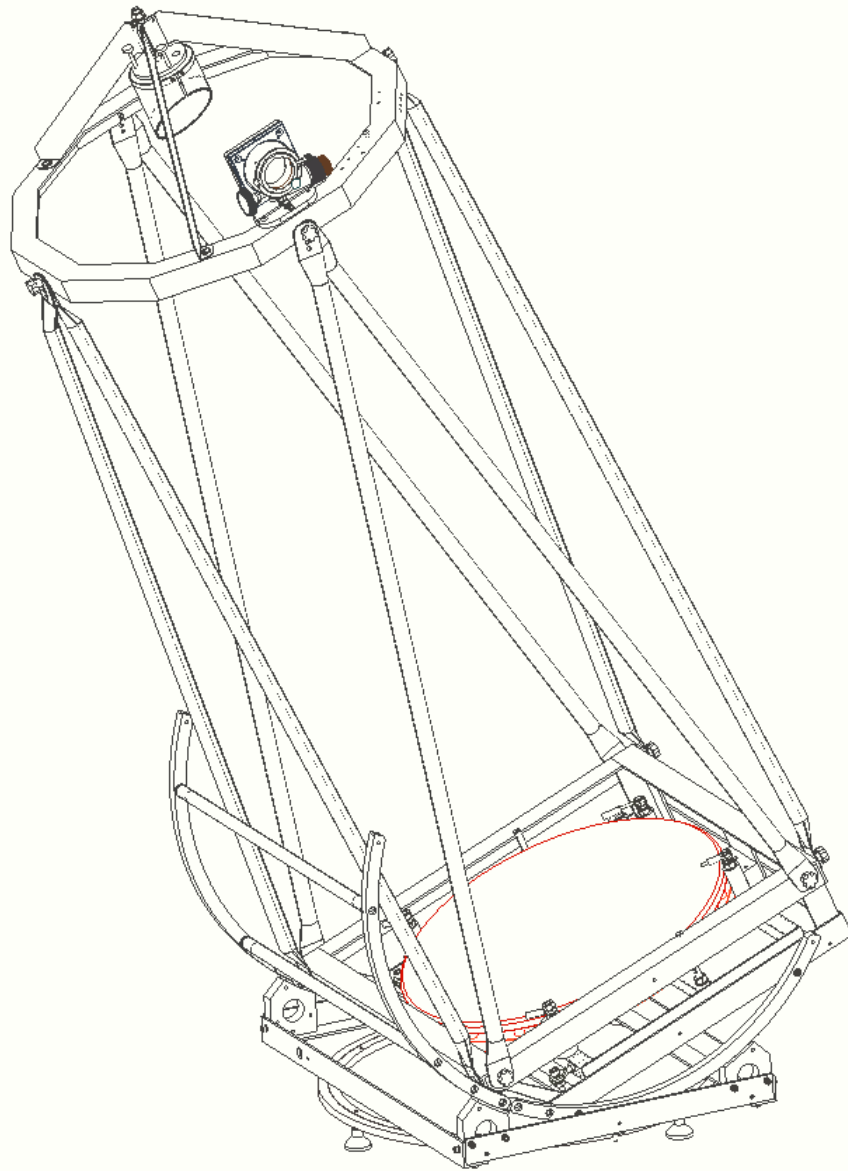

UL20

2. Assembly

Now that you have unpacked the boxes and familiarized yourself with all of the parts in front of you, it's time to begin assembly. You'll need a Regular screwdriver, a Phillips screwdriver, a set of metric hex keys (1.5, 2, 2.5, 3, 4, and 5mm), two 6-inch (150mm or smaller) adjustable crescent wrenches, and a scissor.



Tools Required (Not provided)

2.1 Install the Secondary Mirror

2.1.1 Secondary Mirror Initial Assembly

The secondary baffle is machined from thin aluminum and is designed to flex slightly during assembly. The secondary mirror itself, however, must be handled with extreme care. Proper installation is critical; even slight mechanical compression can distort the mirror's optical figure and degrade image quality.

1. Prepare the Baffle

Remove the five small side screws that secure the secondary baffle to the assembly.

2. Adjust the Housing

Gently open the aluminum baffle enough to allow the mirror to slide inside. Do not force the mirror at any point. If you feel resistance, stop and widen the baffle opening slightly.

3. Insert the Mirror

Carefully slide the secondary mirror into the baffle from the rear. The front face of the mirror should rest lightly and evenly against the front rim of the baffle.

Ensure the mirror is inserted straight. Angling the mirror during insertion may cause the edges to bind against the aluminum and chip.

Note: The edges of the mirror are fragile and must not be subjected to excessive lateral force.

4. Apply the Backing Support

Place the provided fiber ball directly behind the center of the mirror. As this soft material naturally compresses, it will provide uniform support, securely holding the glass against the front lip of the baffle.

5. Secure the Assembly

Reinstall the five side screws to secure the baffle and mirror assembly to the back plate.

6. Baffle Adjustment (if required)

If the baffle feels excessively tight around the mirror after securing the screws, you must relieve this clamping force to prevent pinched optics. Insert the provided thin spacers between the baffle and the back plate. The goal is to fine-tune the fit—eliminating rigid mechanical pressure while ensuring the mirror remains securely supported.

Important Considerations & Common Pitfalls

1. "Pinched Optics" vs. Sagging (The Art of Perfect Tension)

- **The Pitfall:** Treating delicate optical glass like a structural metal part. Users often fall into two extremes: they either clamp the mirror down tightly to prevent movement (causing "pinched optics" where stars look like distorted triangles or seagulls), or they leave it too loose out of fear of breaking it (causing the mirror to shift and constantly lose collimation as the telescope slews).
- **The Sweet Spot ("Optical Snug"):** Securing the mirror is an art of balance. The mirror requires *just enough* clamping force from the baffle and the provided fiber ball to lock it in place so it cannot shift under its own weight. However, it must not be squeezed.
- **The Verification Test:** Once assembled, double-check your work:
 - **The Touch Test:** You should not be able to rattle or slide the mirror with light finger pressure. If it holds its position firmly, stop. Do not add more fiber or tighten the baffle further "just to be safe."
 - **The Visual Test:** Look closely at the metal baffle. It should not look overly tight, stretched, or misshapen around the mirror's perimeter.

2. Protecting the Optical Coatings (Secondary Mirror Only)

- **The Pitfall:** Accidentally touching the reflective face of the secondary mirror. The natural oils and acids from human skin can permanently etch the delicate optical coatings if left uncleaned.
- **The Solution:** Wash your hands thoroughly with grease-cutting soap (like Dawn) and dry them completely before handling the glass. Because the secondary mirror is small and lightweight, you may wear tight-fitting, powder-free nitrile gloves during this step if you prefer—though clean bare hands are perfectly fine. Regardless of your method, **always handle the secondary mirror strictly by its unpolished edges or the back glass surface.** (*Note: Gloves are NOT recommended later when handling the heavy primary mirror, as bare hands are required for a safe grip.*)

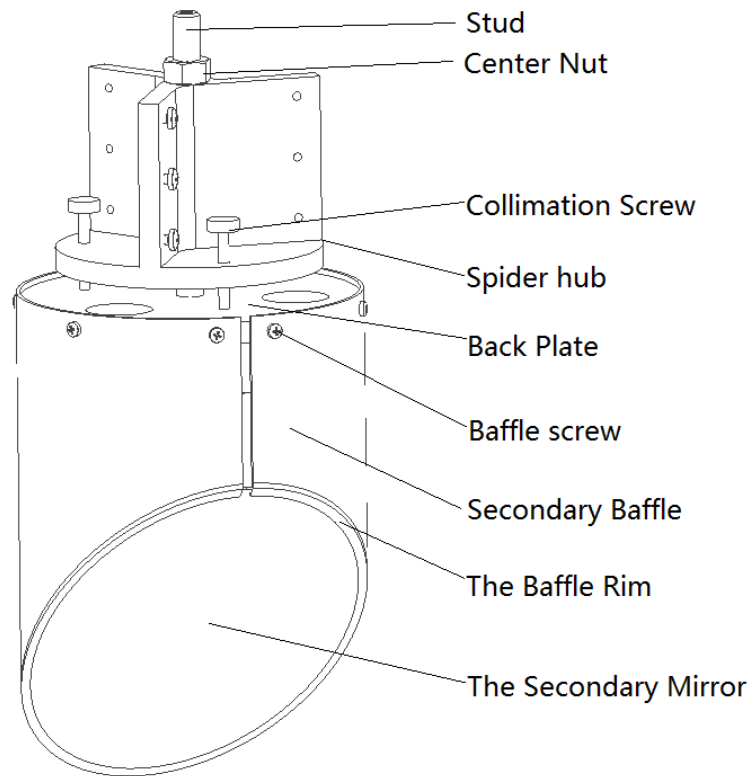

2.1.2 Assembly of the Secondary Cage

Please note that most screws needed for the installation are already installed on the parts for easy identification.

- Attach the three spider wings to the spider holder
- Attach the three spider wings to the upper ring
- Attach the focuser L bracket to the upper ring and tighten the screws
- Attach the focuser to the L bracket and tighten the screws
- Attach the secondary holder with the secondary mirror (installed and cured)
- Roughly adjust the center bolt and the orientation of the secondary holder until the secondary mirror is centered by being viewed from the focuser draw tube
- Adjust and tighten the three collimation screws.

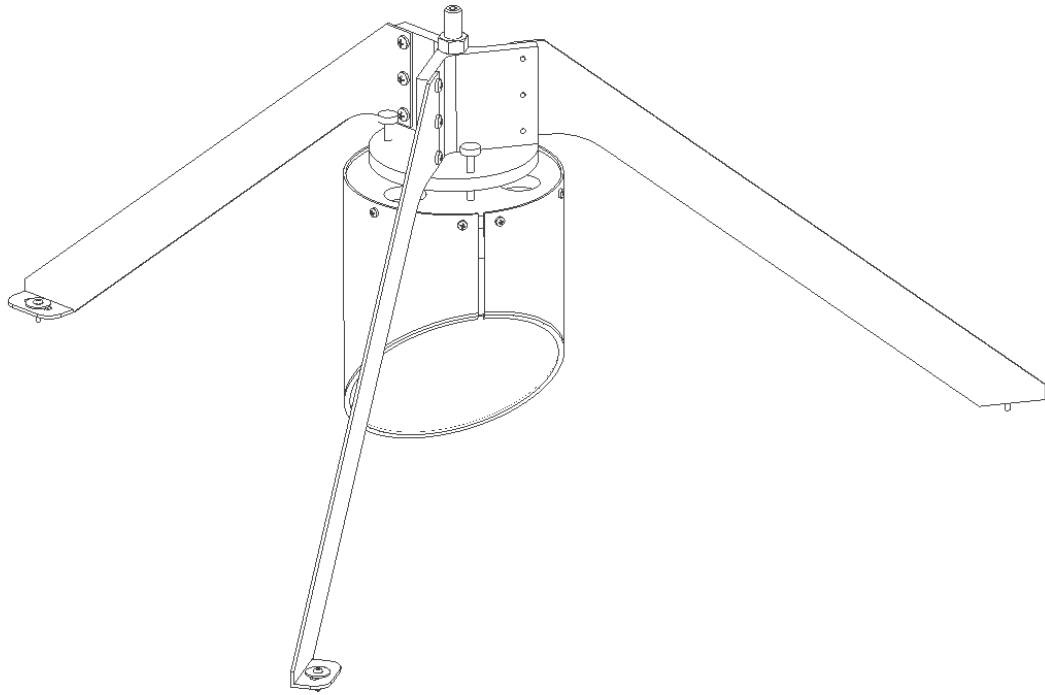

Attach the three spider wings to the spider hub

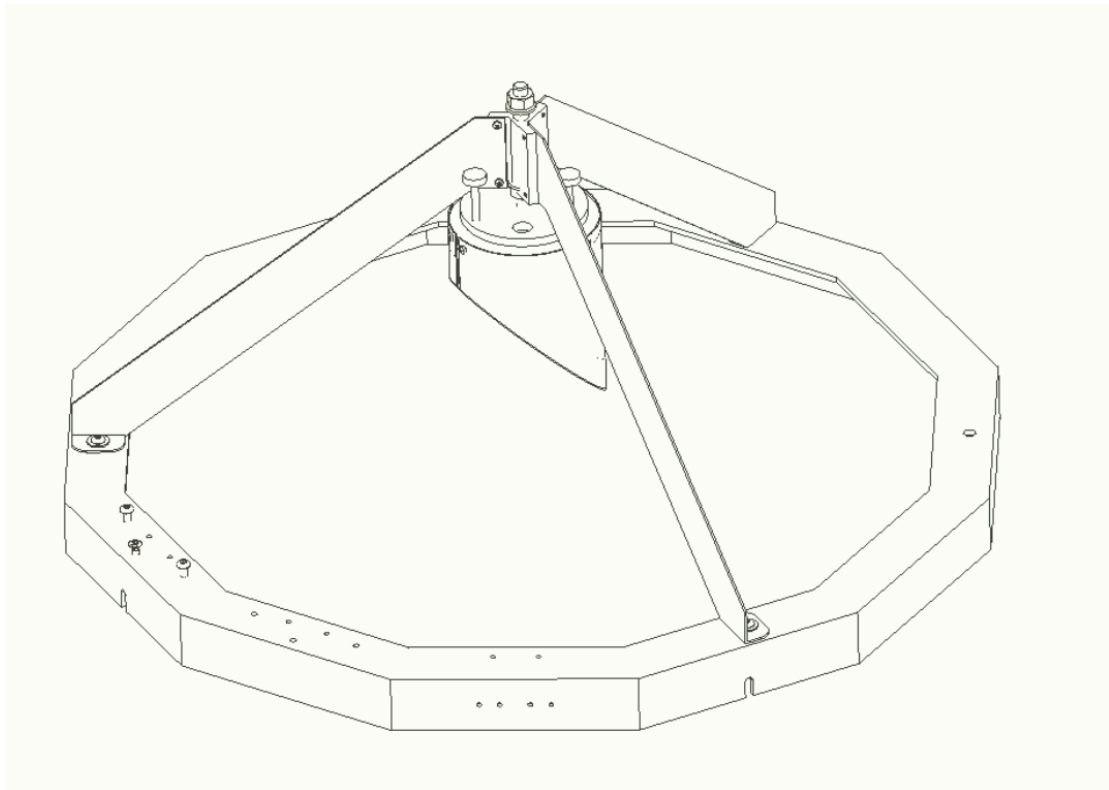

Attach the three spider wings to the upper ring

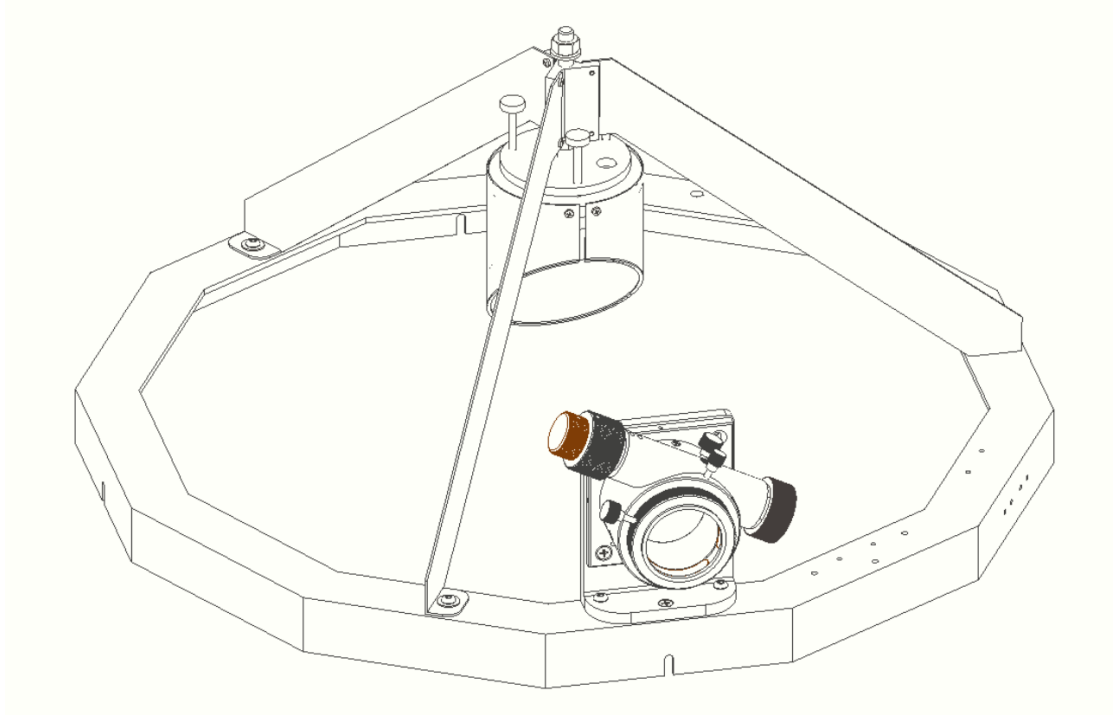

Attach the focuser L bracket and the focuser to the upper ring

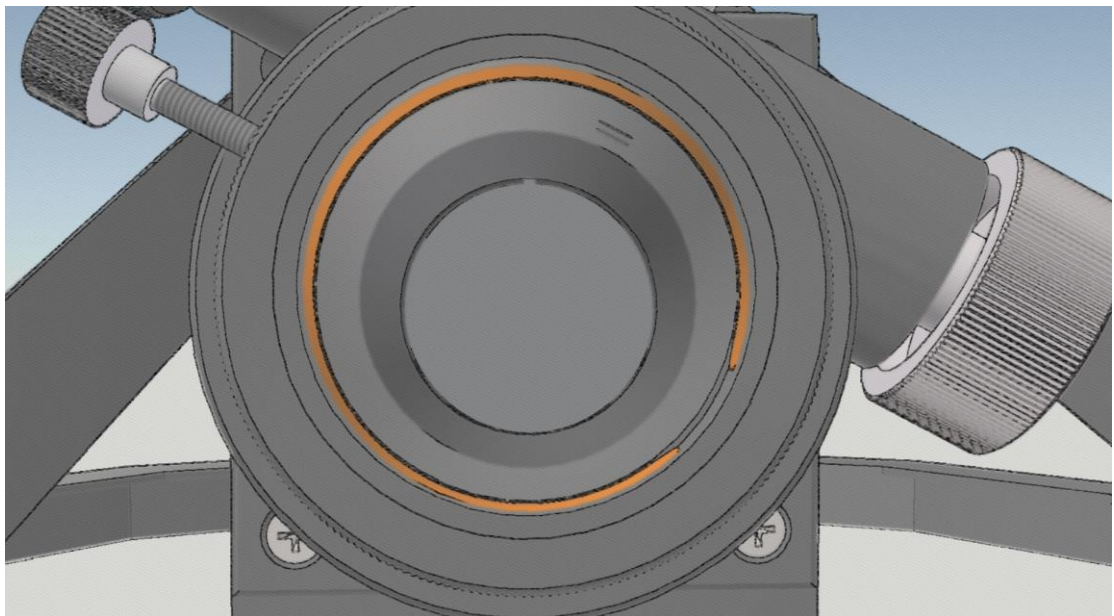

Center the secondary in the focuser draw tube

2.2 Assembly of the Dobsonian Rocker

The UL20 base is shipped assembled, the only thing you need to do is to install the three plastic feet. Make sure to use the wingnut to lock the three feet in their position. When installing the feet, make sure the screws do not protrude up through the board. If a screw sticks up past the surface, it will block the movement of the telescope.

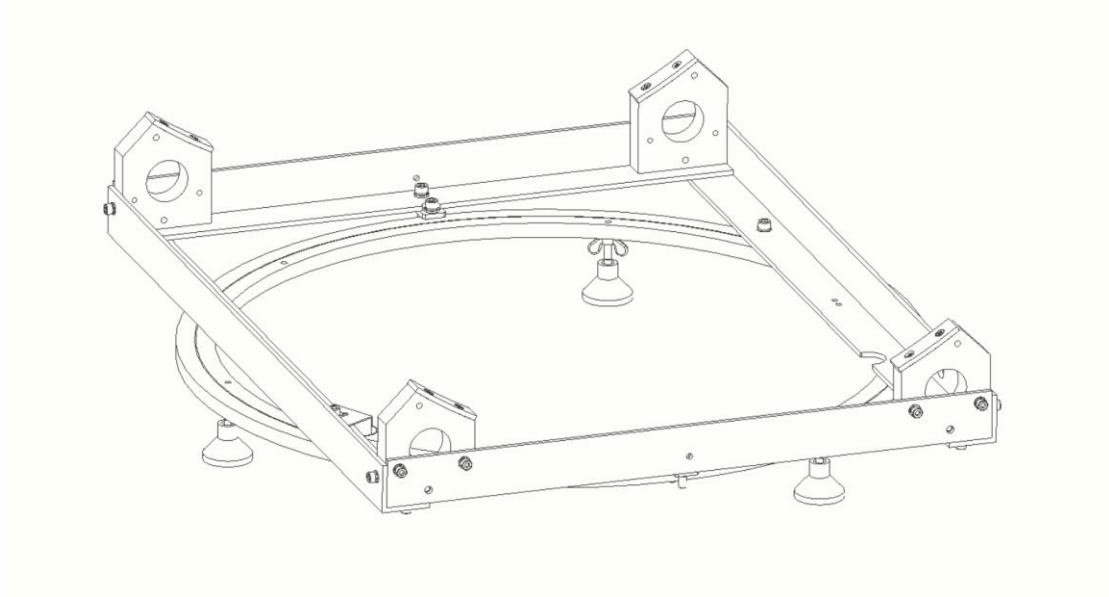

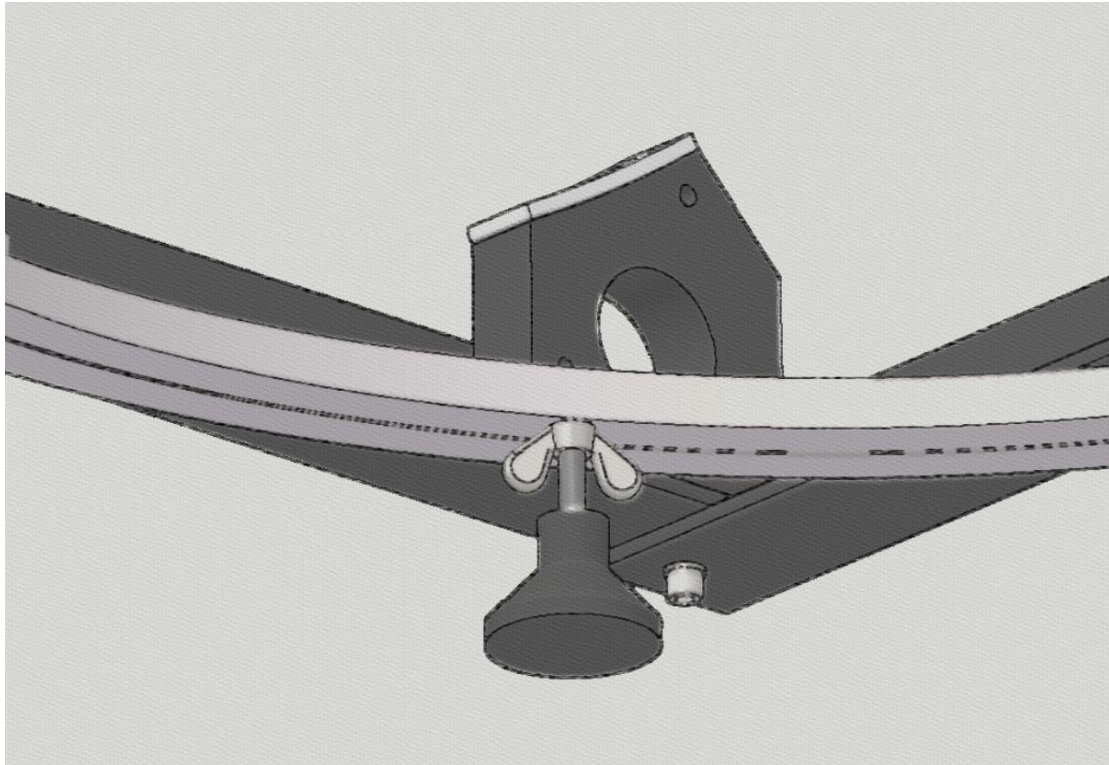

2.3 Assembly of the Mirror Box

The mirror box is very much assembled already; but you do need to install the ALT bearings and load the primary mirror into the mirror box.

Before installing the primary mirror, you need to perform the following tasks:

- Attach the 18 adhesive scratch protectors to the six support triangles - three per triangle, one at each corner where the mirror rests - so the mirror glass never touches bare metal (see the figure below)
- Attach the 9 brass wires to regulate the support bars and angles

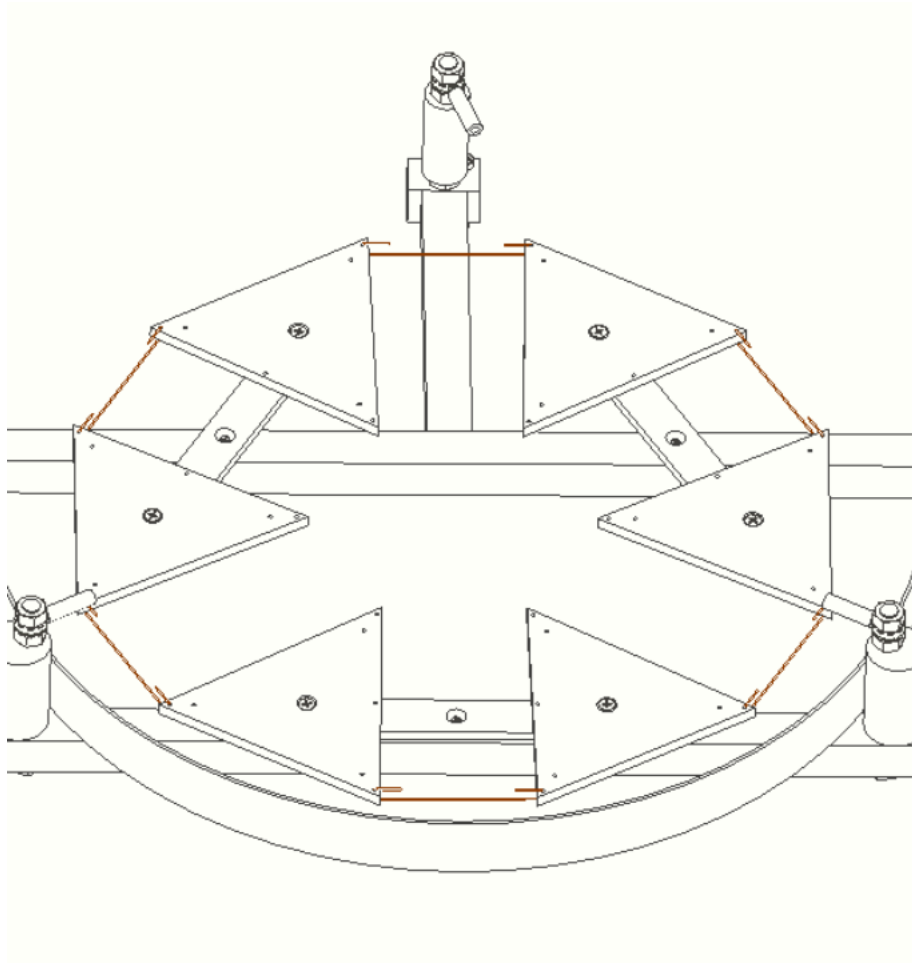

Bend 9 brass wire to the following shape, with the center portion to be about 93.5mm (a bit longer is OK, but all nine should be the same length as much as possible).

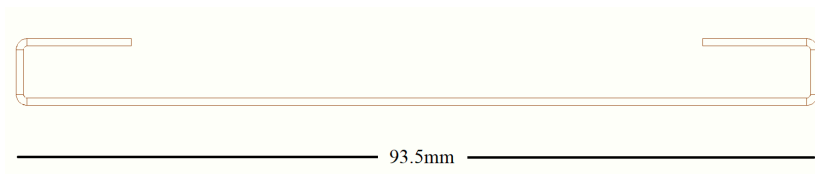

Insert the brass wires into the small holes on the support bars, and then bend the head portions to lock the brass wires in the position.

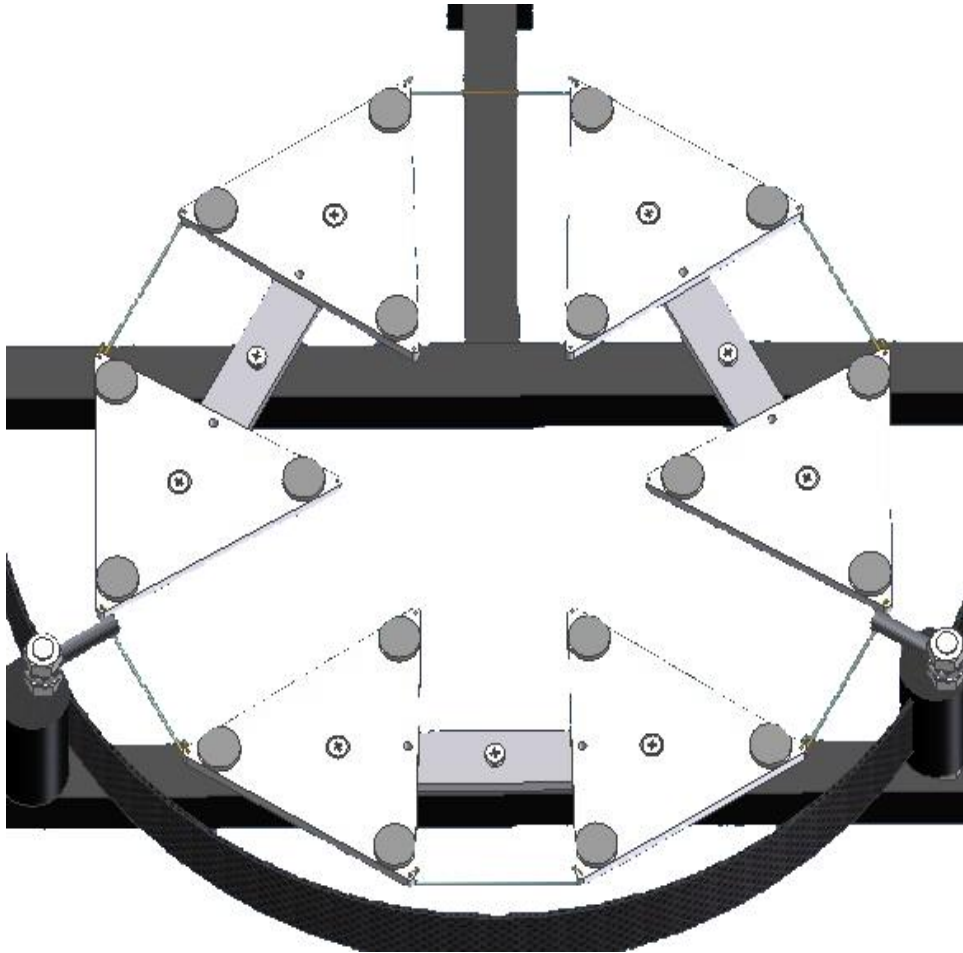

The six support triangles, each fitted with three adhesive scratch protectors at its corners (18 total). The thin diagonal wires are the brass cell-balancing wires.

Please note that the mirror cell in the UL20 features a push-pull design. However, for safety during shipping, the three M5 pushing screws are not pre-installed; they are in a bag with an assortment of screws. This is to prevent any potential damage during transit. Upon receiving your system, you will need to install these three M5 locking screws, which are located adjacent to the collimation knobs.

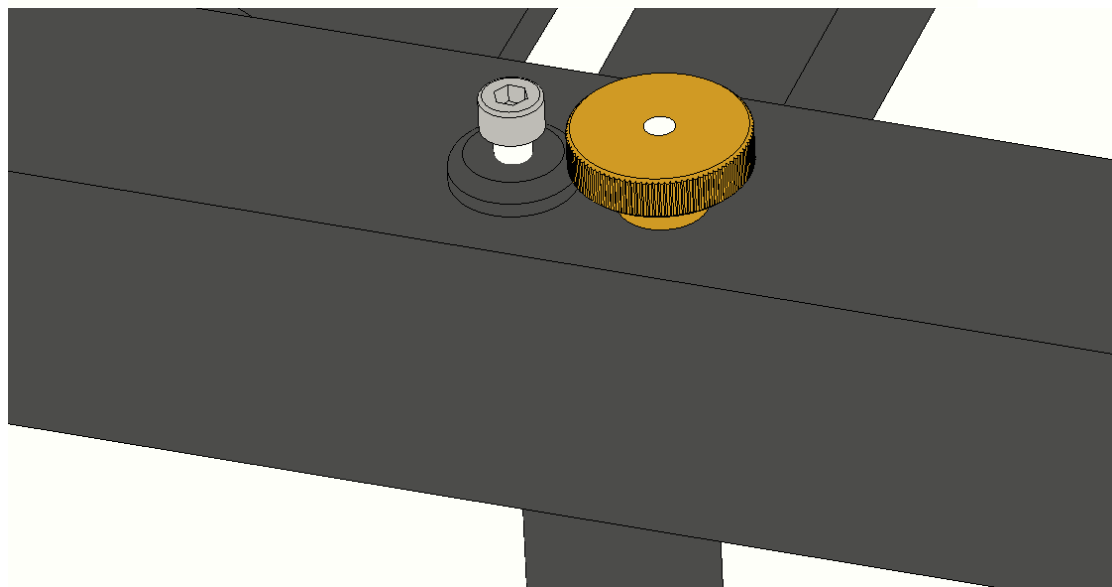
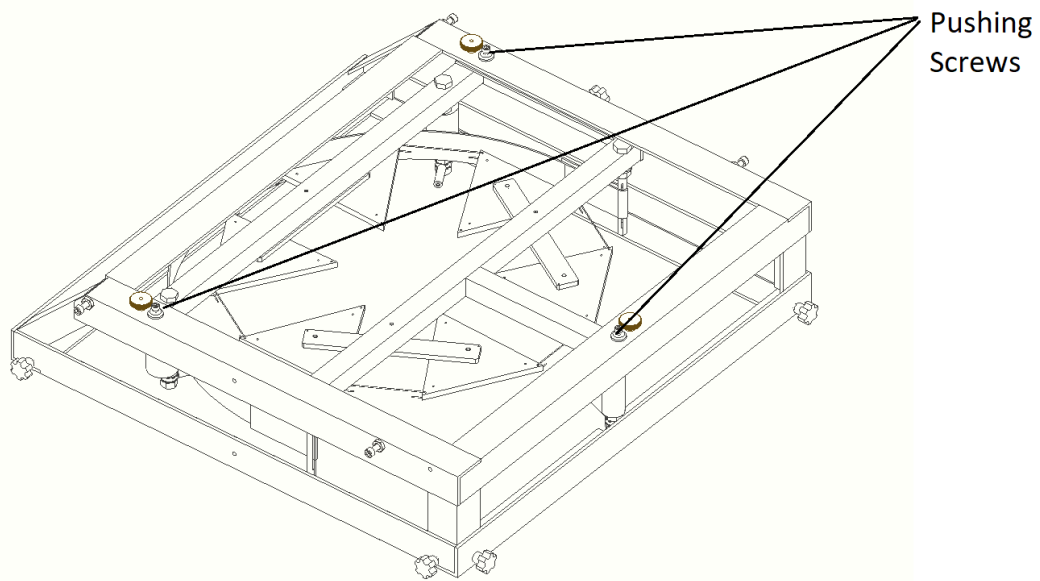

The primary mirror is shipped in its own box. Once the primary mirror is installed in the mirror box, there will be no need to remove the mirror until cleaning is necessary. However, for shipping, long distance transportation, and the long time storage, the primary mirror should be packed tightly in its original package.

2.3.1 Center Spot The Primary Mirror.

The mirror has been centered spot already!

2.3.2 Install the ALT Bearings

Each ALT (altitude) bearing is made of two curved pieces that look very similar - a **lower portion** and a **top portion** - which connect to form one complete arc. **Only the lower portion bolts to the mirror box.**

How to tell them apart: the lower portion has **two countersunk (stepped) holes** whose spacing matches the mounting holes on the mirror box exactly. The top portion does not have these holes.

1. Join the lower and top portions of one bearing together to form the full curved arc, securing them with the provided screws.
 2. Lay the mirror box on its side on a padded surface.
 3. Bolt the lower portion to that side of the mirror box, driving the screws through its two countersunk holes into the matching holes in the box.
 4. Turn the mirror box over and repeat for the second ALT bearing on the other side.
- Once both ALT bearings are joined and bolted to the mirror box, the assembled mirror box should match the drawings on the following pages.

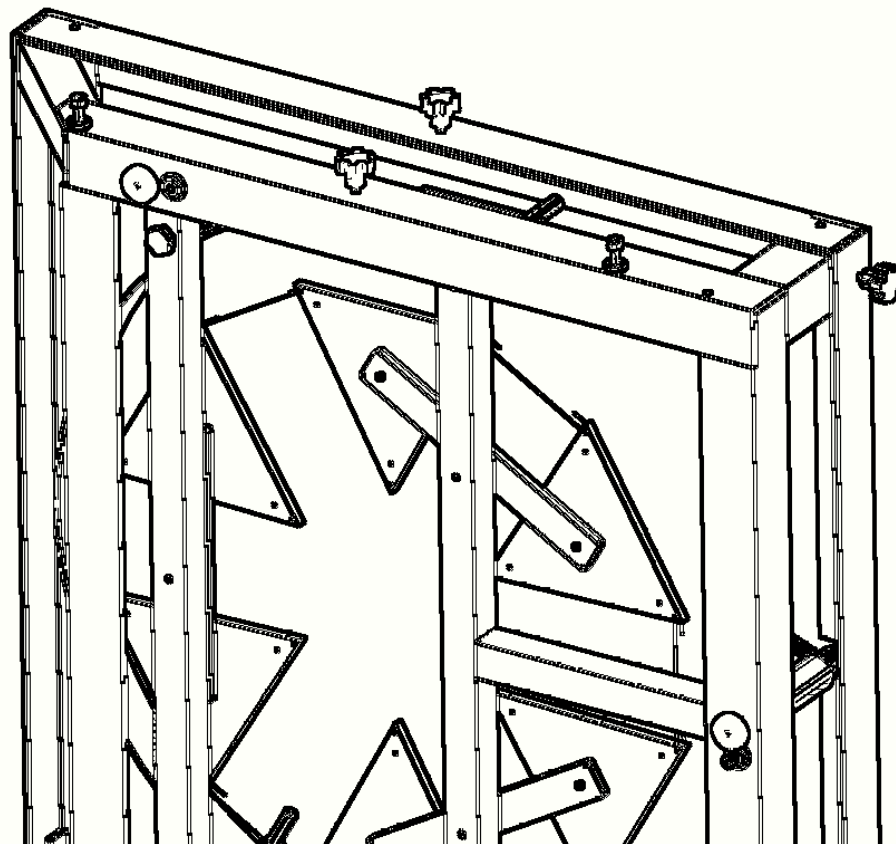

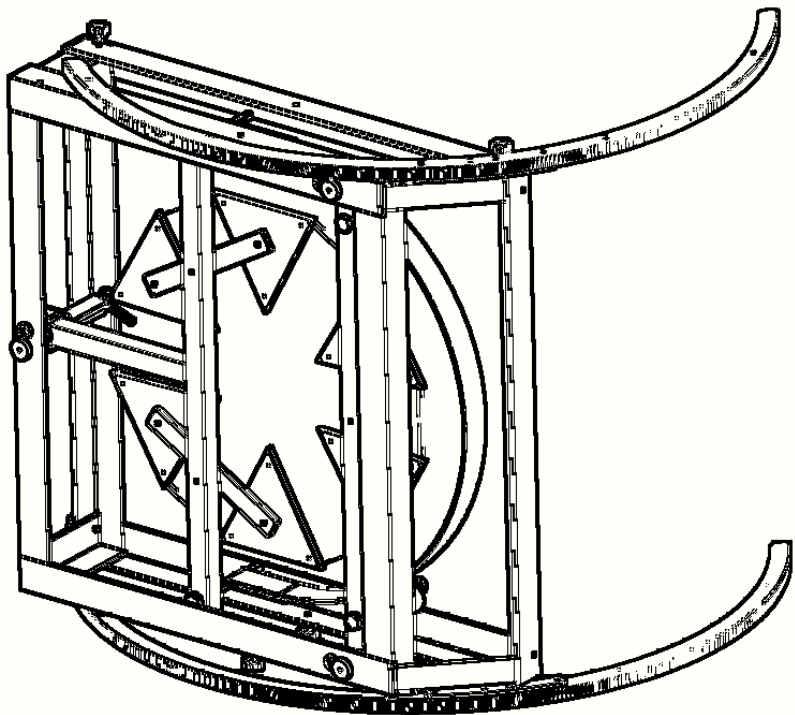
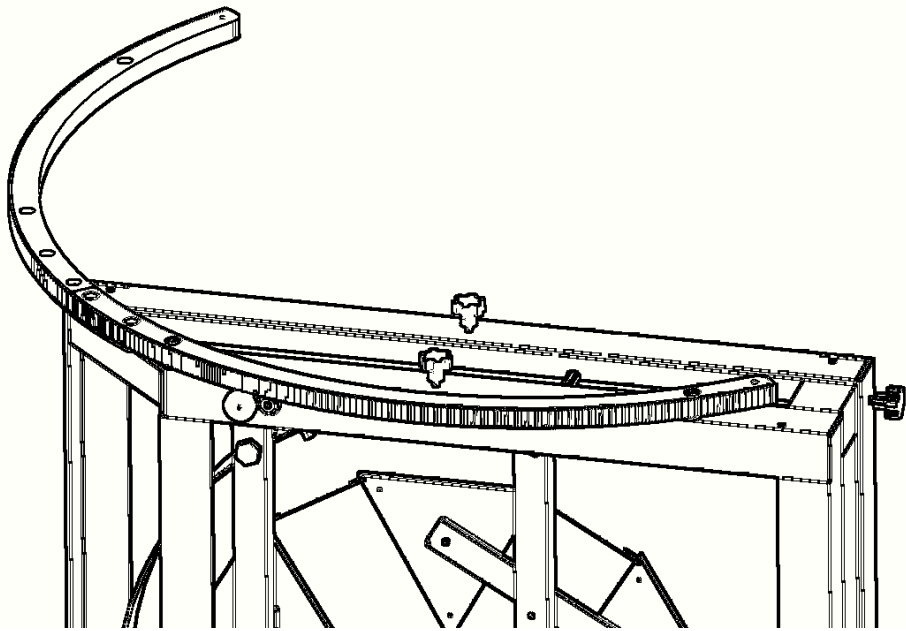

Place the mirror box carefully onto the Rocker/Ground board. The two brackets indicated by the arrows in the figure below are extra reinforcement supports for the ALT bearing. They add rigidity but are optional, and most users do not need them. If you want the additional support, install the two front ALT bearing cross bars as shown:

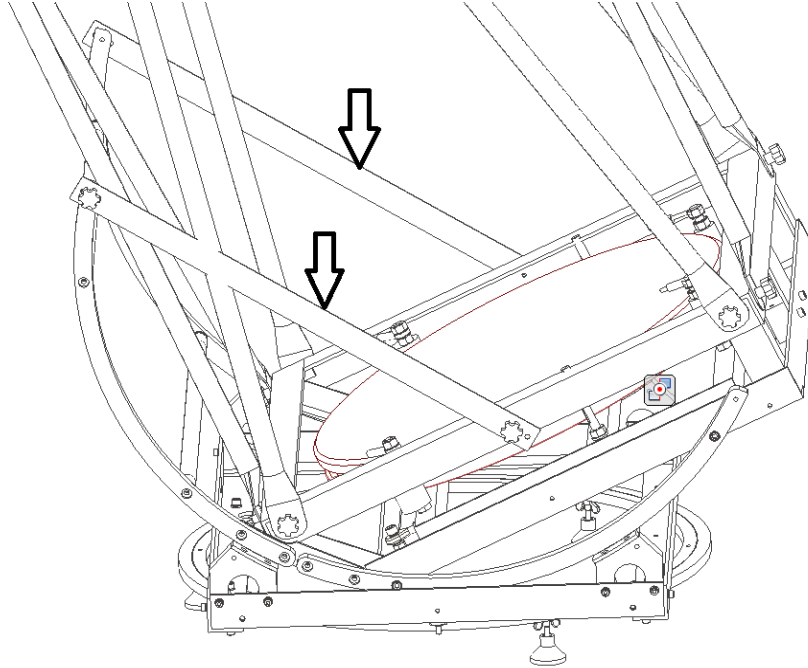

The two optional ALT-bearing reinforcement brackets (arrows). These add rigidity but are not required for most users.

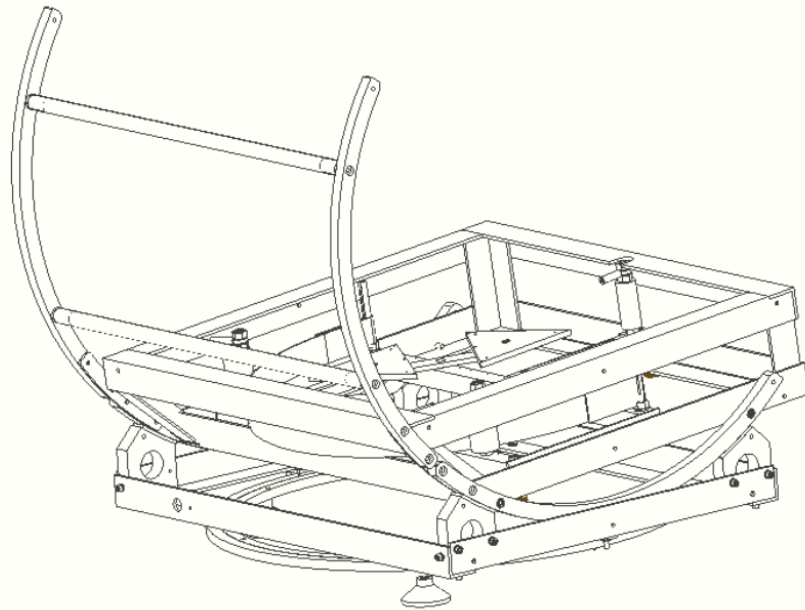

2.3.3 Secure the Mirror Box to the Rocker

The mirror box is locked to the rocker with four nylon strips - two short and two long. Their main purpose is to keep the mirror box secured whenever you lift, move, or transport the assembled telescope. They are not strictly required while loading the primary mirror, but installing them now is recommended, as it keeps the mirror box from shifting on the rocker while you work.

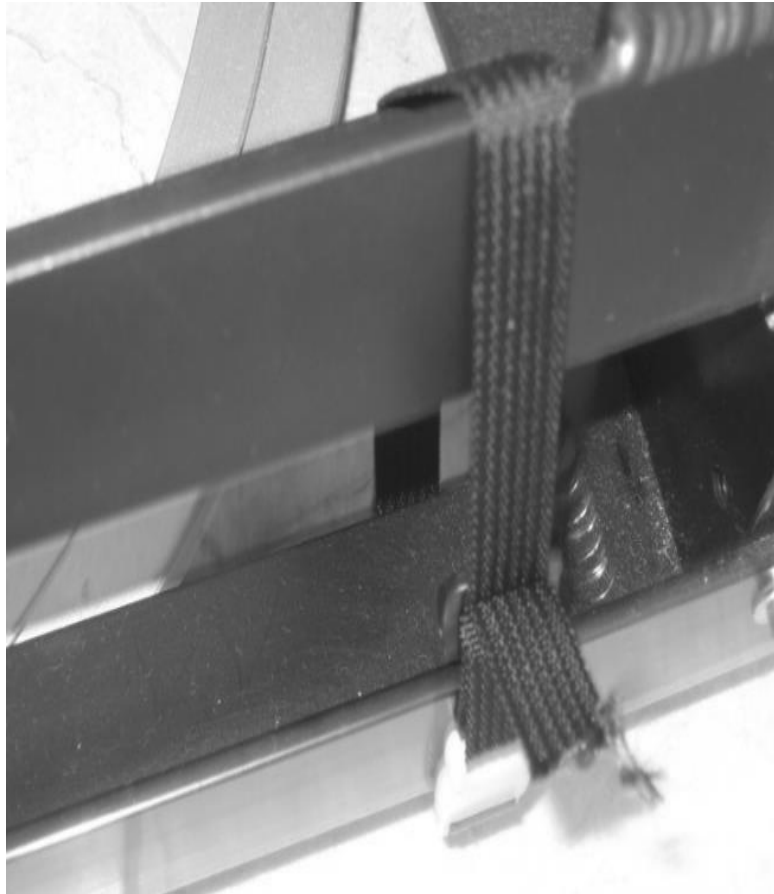

Lock the mirror box to the rocker with nylon strips.



The two long nylon strips on the front side of the mirror box.



The two short nylon strips on the back side of the mirror box.

2.3.4 Install the Primary Mirror

Rotate the three eccentric side pins to make room for the primary mirror. Loosen the locknuts on the top of the mirror clips and turn them aside.

Use a flat head screwdriver to open the split bolts, and insert the sling into the slot. Also loosen the nuts on the two split bolts that hold the sling. Stretch the sling loosely around the two lower side pins.

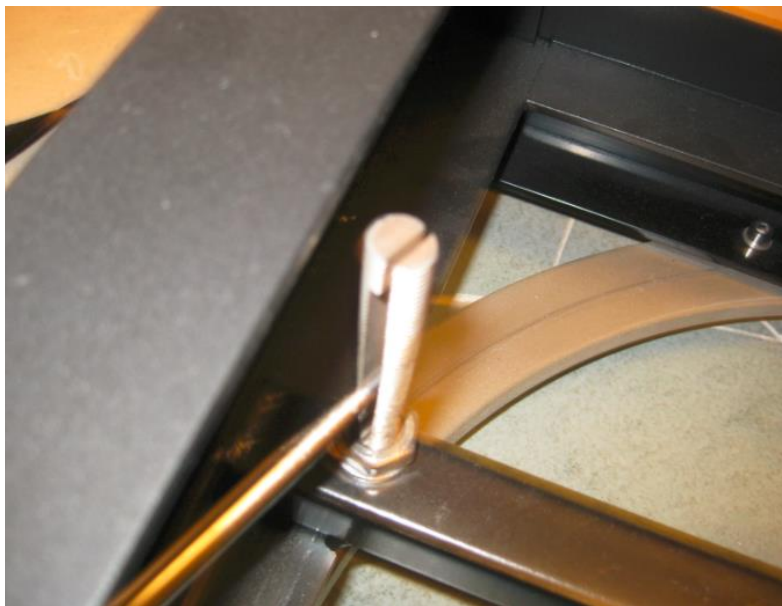

Open the split bolt



Insert the sling

Make sure that all the mirror support bars/triangles are evenly placed in the cell. Pick up the mirror and place it into the mirror cell. Check that the mirror is centered and wiggles it a bit to ensure that the cell parts are moving freely and adjusted to the float of the mirror.

Viewed from the above, the primary mirror should be well centered in the mirror box:

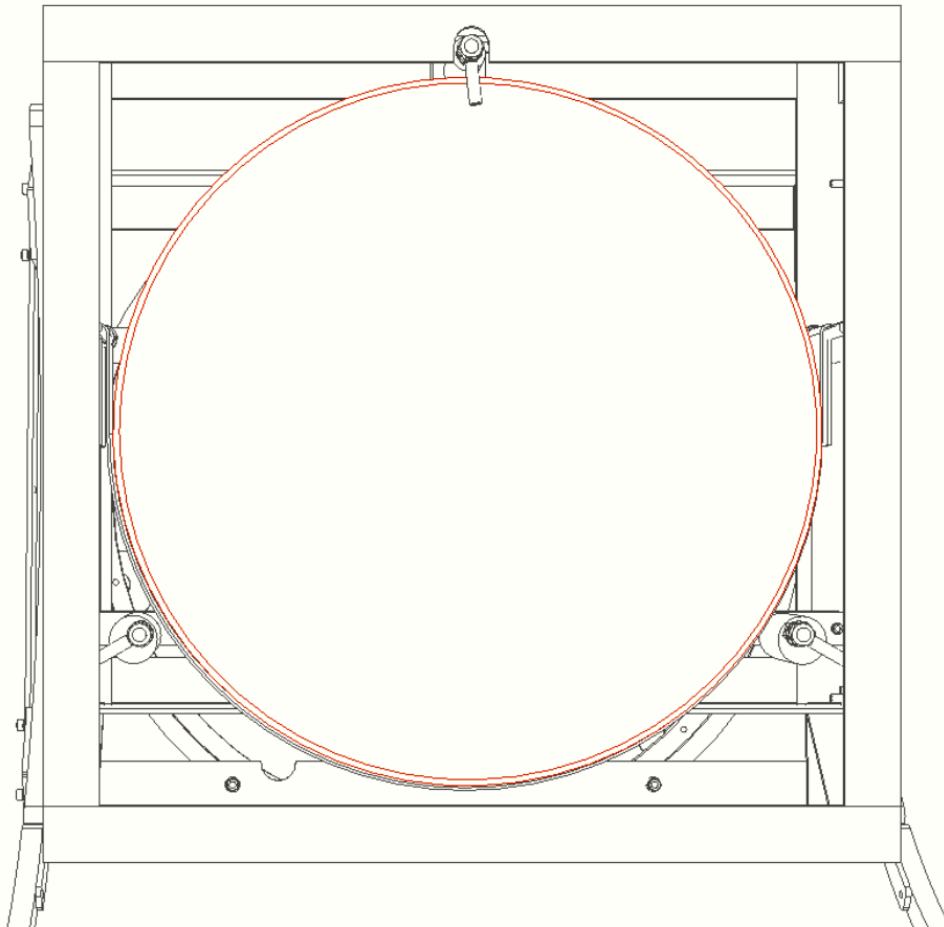

Use a flat head screwdriver to open the split bolts, and insert the sling into the slot. Stretch the sling loosely around the two lower side pins.

1. **Secure the Mirror Box:** Ensure the mirror box is secured to the rocker.
2. **Position the Mirror Support Bars:** Verify that the three mirror support bars, and all the support triangles are evenly distributed within the mirror cell.
3. **Install the Mirror:** Carefully place the mirror into the mirror cell. Center the mirror and gently wiggle it to confirm that the cell components move freely and are properly adjusted to accommodate the mirror's float.
4. **Install the Sling:** Position the sling between the side pin and the mirror's edge. Adjust the two lower pins so that there is a gap between the sling encircling the mirror and the side pins.
5. **Side Pin Adjustment:** Ensure the side pins do not contact the mirror during observation. If the primary mirror touches the pins, reposition the sling and adjust the side pins as needed. Securely tighten the nuts holding the side pins.
6. **Mirror Protection Clips:** Adjust the mirror protection clips so they hover 3-6mm above the mirror surface, without touching the mirror. Secure the clips over the mirror and tighten the top lock nuts.

7. **Sling and Magic Nylon Tape:** At this stage, the sling should be loosely fitted around the mirror. Leave the sling loose for now; final adjustments will be made after the telescope is fully assembled.

Apply a short piece of the provided magic nylon tape at the lowest part of the mirror, which will rest in the bottom of the sling. Ensure the sling is centered, with equal portions of the mirror above and below it. The magic tape prevents the sling from slipping off when the telescope is pointed upwards.

The bottom side pins should not contact the mirror/sling during observation. **However, the top side pins should lightly touch/support the mirror.**

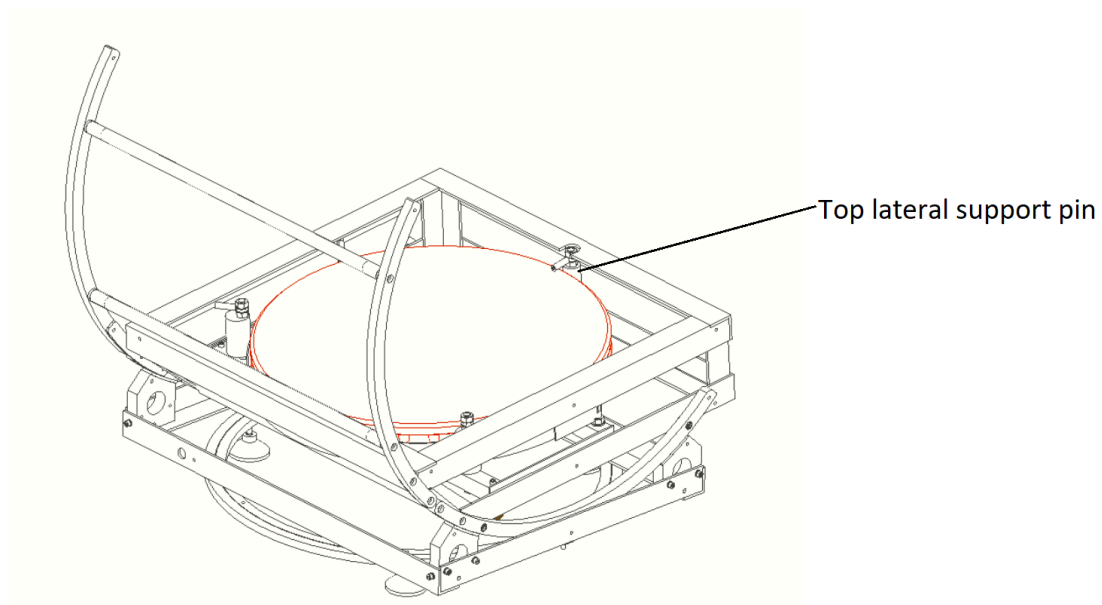

2.4 Install The Truss Tubes and Secondary Cage

2.4.1 Installation of the Truss Tubes

1. **Asymmetric Truss Tube Ends:** The ends of the truss tubes are asymmetrically shaped to enable connection in opposite orientations. This design helps to avoid interference between the tubes during assembly.
2. **Primary Mirror Protection:** Ensure that the primary mirror is fully enclosed and protected. A mirror box cover is recommended for this purpose.
3. **Truss Tube Connection:** Attach each pair of truss tubes using an M6 knob screw, and secure it with an M6 wing nut. This connection should be made on the side of the tube that has multiple holes. These multiple holes allow for adjustments in the overall tube assembly length, which is necessary to accommodate slight variations in the primary mirror's focal length. Typically, the second hole from the top is the recommended starting point for this connection.
4. **Attaching Truss Tubes to Mirror Box:** Finally, connect each pair of truss tubes to the mirror box using an M6 knob screw.

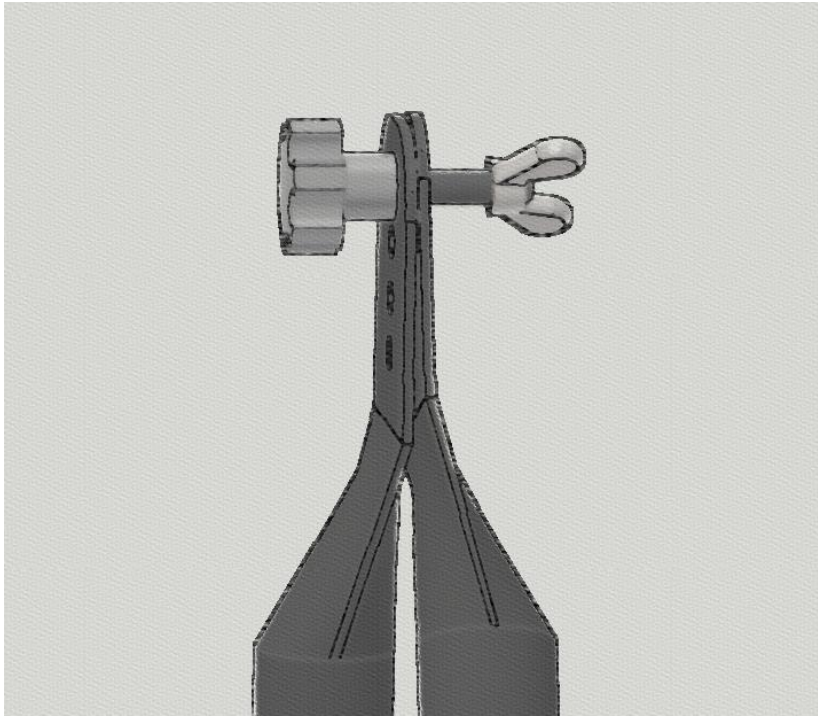

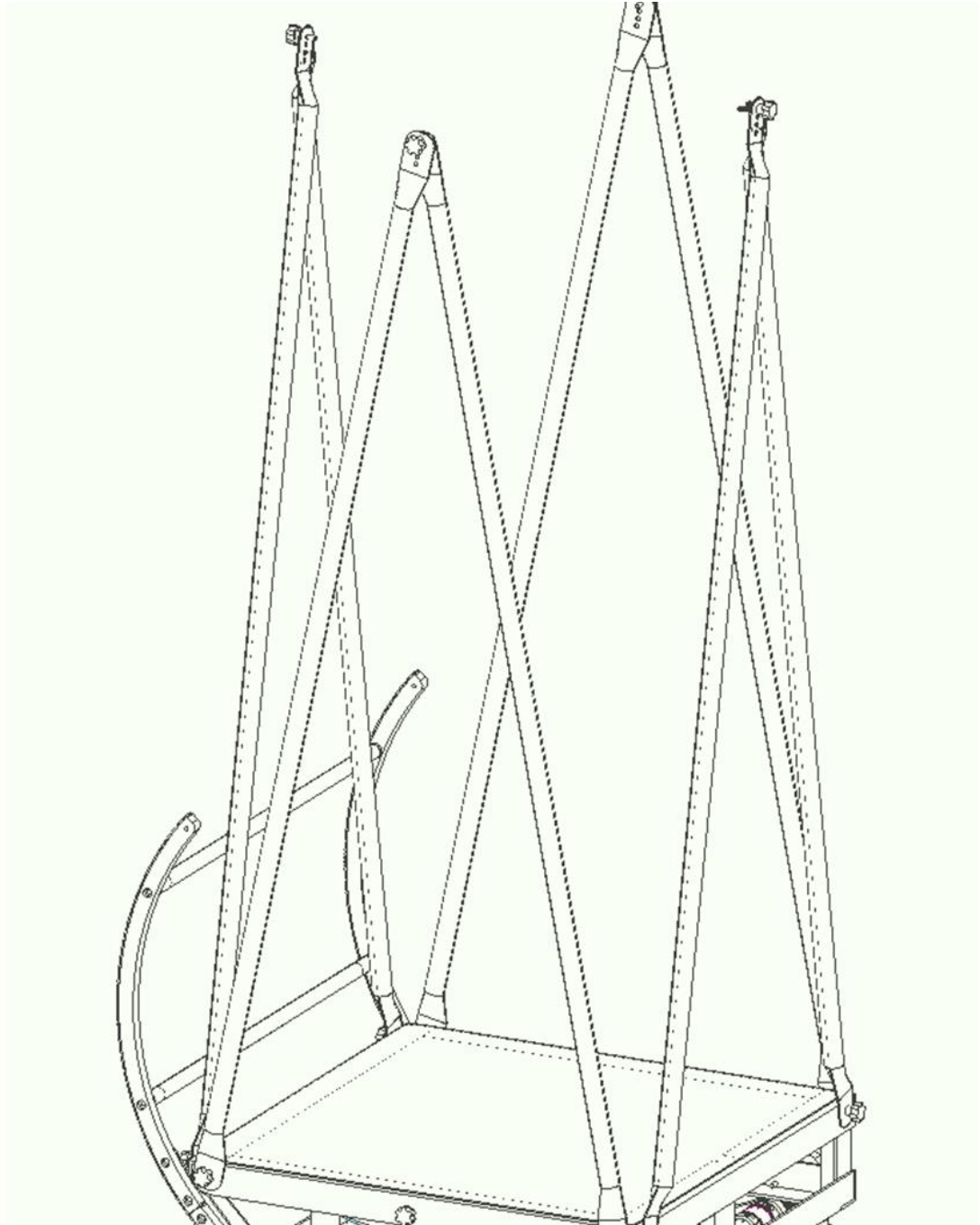

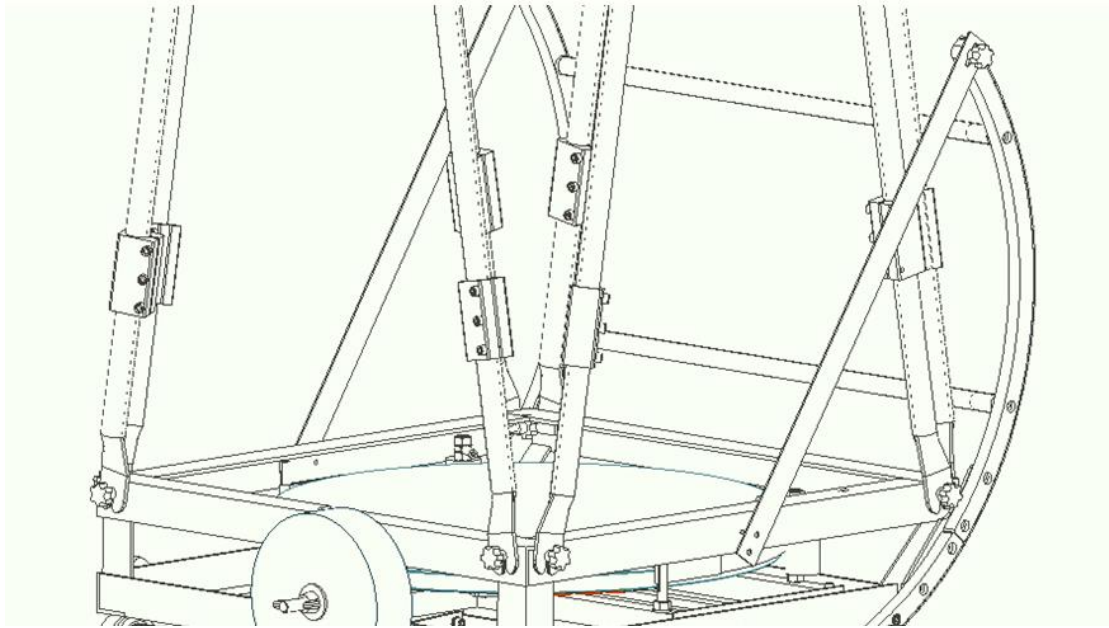

2.4.2 Installation of the Secondary Mirror Cage

Make sure that the primary mirror is fully protected with a mirror box cover. Then carefully install the upper ring on to the top of the truss tubes. Tighten all the top and bottom truss tubes locking screws once the upper ring is positioned correctly.

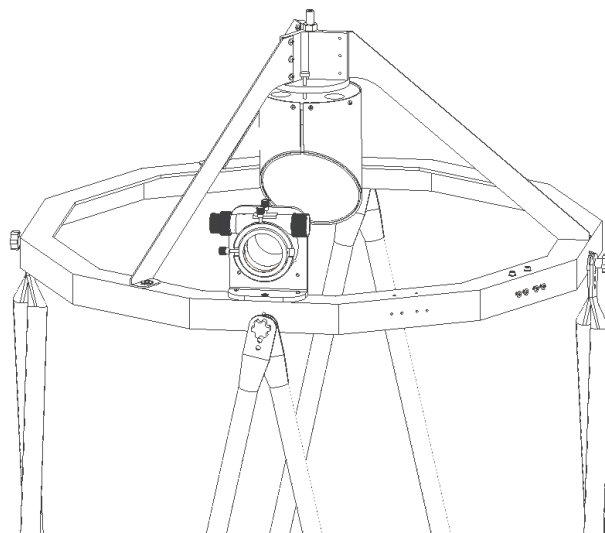

2.4.3 Installation of the Optional Finder Scope

Use 2 provided (hexagon or cross) socket sunk head screws to mount the finder scope base to the upper ring.

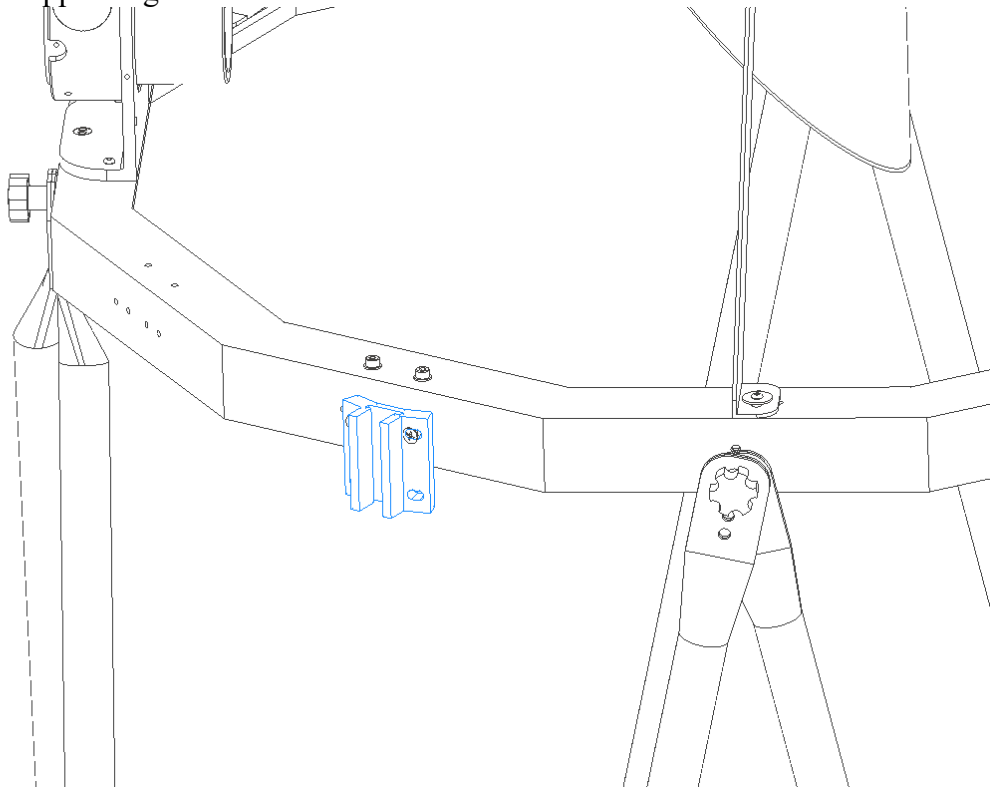

2.5 Adjust the Sling

After UL20 is fully assembled, the sling must be adjusted.

The primary mirror must be supported in the sling and not by the side pins. Point UL20 about 60° above the horizon in manual mode, an angle from which you can comfortably reach and adjust the collimation screws.

You will need to use two wrenches to adjust the sling. Make sure that the sling is hung through the slot on the left (or right) split bolt. Just wrap one or two turns on this side. To do this, rotate the head of the bolt with one wrench and hold the opposing nut with other wrench. Lock it tight.

Now go to the sling bolt on the other side. Hold the bolt head with one wrench and loosen the opposing nut. Turn the bolt to wrap the sling until the mirror lifts off the two lower pins. Raise the mirror until it almost touches the upper side pin.

Lock the bolt in this position by tightening the lock nuts. Check to make sure that the mirror is indeed suspended on the sling by pushing on the back of the mirror with your fingertips. With UL20 in a nearly horizontal position, you should be able to move the mirror off the floatation cell support bars easily.

If the mirror tilts against one of the side pins, loosen the retaining nuts and rotate that pin away from mirror until there is a few mm gap between the mirror and the pin.

The mirror must be supported by the sling and not by the side pins.

3. Collimation: Mandatory Pre-Observation Alignment

For a large Dobsonian Newtonian telescope such as the UL20, collimation is not a one-time factory setting—it is a required part of normal operation. Proper alignment must be checked after assembly, after any transport, and before each observing session.

Even slight misalignment will noticeably degrade image contrast and resolution.

With a little practice, this process becomes a quick and routine part of setup.

Pre-Collimation Checklist

Stable collimation is impossible without a stable mechanical structure. Before making any optical adjustments, verify the following:

- **Cover the Primary:** Keep the primary mirror covered during the initial steps to protect it from dropped tools
- **Telescope Position:** Position the telescope approximately 60° above the horizon. This simulates a realistic observing angle and allows the mirrors and structure to settle naturally
- **Mechanical Check:** Ensure all structural connections are firmly secured, including:
 - Focuser and focuser base
 - Upper ring and rotator connections
 - Spider vanes and secondary holder
 - Secondary mirror collimation screws (after adjustment)
 - Truss tube connections
 - Primary mirror locking screws
- **Structural Stability:** Collimation should remain consistent as the telescope moves in altitude. Any looseness in the structure will affect alignment
- **Focuser Mounting (Recommended):** For maximum collimation stability under load, mount the focuser directly on top of the side truss tubes. While

multiple mounting positions are available for convenience, this position provides the best rigidity

Step 1: Center the Secondary Mirror (Geometry)

This step establishes the correct physical position of the secondary mirror beneath the focuser so it fully intercepts the light cone from the primary mirror.

1. Inspect the Alignment

Insert a collimation cap or sight tube into the focuser and look through it.

Note: If a tool is not available, you may approximate by viewing through the empty focuser from a short distance, keeping your eye centered with the drawtube.

2. Correct Condition

The secondary mirror should appear as a round, symmetrical circle centered within the focuser opening.

If it appears oval or offset to one side, its position must be adjusted.

3. Make Mechanical Adjustments

- **Vertical position (up/down the tube):**
Adjust the central mounting bolt of the secondary holder to move the mirror toward or away from the primary mirror
- **Lateral position (side-to-side):**
Adjust the tension of the spider vanes to center the secondary holder within the upper cage

Important: Do not adjust the tilt (collimation) screws at this stage. This step is for positioning only.

4. Refine and Verify

Make small adjustments and re-check the alignment after each change. Continue until the secondary mirror appears centered and circular.

Step 2: Align the Secondary Mirror (Laser Required)

This step aligns the focuser axis precisely with the center of the primary mirror. A laser collimator is imperative for this step.

1. Prepare the Laser Remove the primary mirror cover. Insert the laser collimator fully into the focuser and secure it squarely.

2. Observe and Adjust Turn on the laser. Looking down the front of the telescope, locate the laser dot on the primary mirror. Carefully adjust the three tilt screws on the secondary mirror holder to steer the beam.

3. Correct Condition The laser dot must rest exactly inside the center marker, or “donut” ring, on the primary mirror.

4. Refine and Verify Make very small, incremental adjustments to the tilt screws. Because the laser beam travels a long distance down the truss tubes, even a small turn of a screw can move the dot significantly. Re-check the dot position after every adjustment until precise center alignment is achieved.

Step 3: Align the Primary Mirror (Critical Step)

This is the most critical step in the collimation process. It aligns the optical axis of the primary mirror back to the focuser.

1. Observe the Return Beam

Look at the angled target face of the laser collimator in the focuser. You will see the returning laser beam reflected from the primary mirror.

2. Adjust the Primary Mirror

Using the primary mirror collimation knobs at the bottom of the telescope, adjust the tilt of the primary mirror.

- Turn one knob at a time
 - Make small, controlled adjustments
 - Observe how the returning beam moves across the collimator target
-

3. Correct Condition

The returning laser dot must be centered precisely over the center hole of the collimator's target.

4. Lock and Verify

If your mirror cell uses locking screws, gently snug them after adjustment to hold alignment. Do not overtighten, as this can shift the collimation or introduce mechanical stress.

Always re-check the laser position after tightening to confirm that alignment has not changed.



The primary mirror is not yet collimated.



The primary mirror is not yet collimated.



The primary mirror is collimated by laser collimator.

Important Notes & Best Practices

- **Atmospheric Seeing:** Atmospheric conditions will heavily affect the appearance of the star's image. Conduct this test on a night with stable and clear atmospheric conditions for the best results; otherwise, the defocused image will appear to "boil" or shimmer.
- **Ongoing Maintenance:** Collimation should be checked at the start of every observing session. It is also advisable to verify alignment periodically throughout the night, as temperature changes and normal handling can cause slight shifts in the telescope's mechanical structure.

4. Care and Maintenance

4.1 ALT Bearing Surface Maintenance

You should use the Pledge® cleaning wipes /spray (or other furniture wax) to clean and condition the ALT bearing surface before use it for the first time. Then, you should do it about every 6 months to achieve the optimal performance.



4.2 Scope Storage

Your telescope should be stored in a clean, dry, and dust-free environment, protected from rapid changes in temperature and humidity. It is not advisable to store the telescope outdoors. Storing it in your garage or shed might be acceptable, but this is not recommended. We highly recommend storing the secondary cage and the mirror box in our optional waterproof nylon storage bag. While the bag is sufficiently large, avoid storing the rocker/ground board with the mirrors in the bag for extended periods.

The potential evaporation of lubricants used in the azimuth bearing, especially under high temperatures, can be harmful to the mirror's coating.

4.3 Mirror Cleaning

You should not have to clean the mirror often. The best thing you can do to keep your mirror is to prevent it from getting dirty in the first place! A simple air-blow cleaning, using an optical air dust blower is the next best thing you can do.

5. Specification

- Optical design : Reflector
- Optical diameter : 508mm
- Focal length : ~1676mm (f/3.3), ~1880mm (f/3.7), ~2134mm (f/4.2)
- Focal ratio : ~f/3.3/3.7/4.2
- The focuser height at zenith: ~1490mm(~59 in, f/3.3), 1745mm (~69 in, f/3.7), 2000mm (~79 in, f/4.2)
- Optics type : Parabolic
- Eyepieces: Not included
- Optical quality : Diffraction limited++ (Strehl 0.95+ for the primary mirror, 1/10 lambda or better for the secondary mirror)
- Finder scope : Not included
- Focuser : 2" dual-speed linear bearing Crayford
- Secondary mirror obstruction : 100 mm
- Secondary mirror obstruction by diameter : 19.7% (f/3.3, f/3.7), 17.7%(f/4.2)
- Secondary mirror obstruction by area : 3.9% (f/3.3, f/3.7), 3.1% (f/4.2)
- Mirror coatings/over-coatings : 92% Semi-Enhanced Aluminum coating on the primary and 96% Enhanced coating on the secondary mirror
- Tube material : 6063-T6 Aluminum Alloy tubes with black stainless steel knob screws; Aluminum Alloy main structure (OTA and mount) and structure steel mirror cell.
- Length of optical tube : 73 in (f/3.3, f/3.7), 83 in (f/4.2)
- Weight, optical tube : 76.0 lbs.
- Weight, fully assembled : 88.0 lbs.
- Other features: Sling lateral support and deluxe push-pull brass knob collimation screws
- Optional accessories:
 - 9x50 Finder,
 - Truss Carrying Bag
 - Shroud,
 - Wheelbarrow,
 - Vinyl foam Cushioned Grips
 - Mirror Cover
 - Scope Cover
 - GoTo+ Drive System
 - Wireless/USB DSC
- **Wireless DSC Ready!**

6. Limited Warranty

Hubble Optics (Optel Engineering Group Inc.), Seller, warrants to the original purchaser only, that goods sold will be free of material defects in design, materials and workmanship for a period of one year following the date of shipment by Seller to Buyer. Seller will repair or replace, or refund the purchase price as to, goods that do not conform to the foregoing warranty, provided the cause of the nonconformity does not arise from or relate to modification, misuse, or abuse by the customer, and provided a warranty claim, stating in writing and with reasonable particularity the claimed nonconformity, and the goods, are delivered to Seller within the one year period. Repair or replacement of the product or refund of the purchase price, at Seller's sole option, shall be the Buyer's exclusive remedies. Seller shall not be responsible for any indirect, special or consequential damages arising from use of the products. This warranty is given in lieu of any other warranties, express or implied, including of performance, merchantability, fitness for particular purpose, or arising from course of dealing or usage of trade. Goods subject to this warranty must be shipped postage pre-paid by Buyer to the Seller. Some states do not allow the exclusion or limitation of incidental or consequential damages, so the above limitations may not apply to you. This warranty gives you specific legal rights, and you may also have other rights, which vary from state to state.

7. Technical Support

Hubble Optics (Optel Engineering Group Inc.) will provide the support for the basic operations outlined in this document by email. You will receive a response, generally within 24 hours.