

Hubble Optics Ultra Light UL16 Dobsonian instruction manual

REV: 06-03-2026

Please read these instructions thoroughly before beginning assembly and subsequent use of the telescope.

1. Unpacking	2
2. Assembly	4
2.1 Install the Secondary Mirror	4
2.1.1 Install the Secondary to the diagonal holder.....	4
2.1.2 Assembly of the Secondary Cage	5
2.2 Assembly of the Dobsonian Rocker	8
2.3 Assembly of the Mirror Box	9
2.3.1 Center Spot The Primary Mirror.....	11
2.3.2 Install the ALT Bearings.....	11
2.3.3 Install the Primary Mirror	14
2.4 Install The Truss Tubes and Secondary Cage.....	18
2.4.1 Installation of the Truss Tubes.....	18
2.4.2 Installation of the Secondary Mirror Cage.....	21
2.4.3 Installation of the Optional Finder Scope	22
2.5 Adjust the Sling.....	22
3. Collimate the Optics.	23
4. Care and Maintenance	27
4.1 ALT Bearing Surface Maintenance	27
4.2 Scope Storage.....	28
4.3 Mirror Cleaning	28
5. Specification	28
6. Limited Warranty	29
7. Technical Support	30

WARNING: Never look at the sun with your telescope without a professionally made solar filter. Permanent eye damage or blindness could result. Eye damage is often painless, so there is no warning until it is too late. Children should not be allowed to handle the telescope. Avoid using the type of solar filter that screws into an eyepiece. They are susceptible to cracking under the intense heat that builds up near the focus point, and could cause severe retinal damage. Use only the type of solar filter that covers the front of the telescope. Also, be sure to

leave the cover caps on the finder scope when solar observing. Remove the finder scope altogether when viewing the sun.

1.Unpacking

The UL16 telescope is packed in 4 shipping boxes, as described below. We recommend keeping the original packaging for the future usage.

Make sure all the parts in the Parts List are present. Be sure to check all boxes carefully, as some parts are very small. If anything appears to be missing or broken, immediately email Hubble Optics for assistance.

Box #1: the Primary Mirror

Box #2: the Rocker/Ground board/Upper Cage

Box #3: Mirror Box

Box #4: Truss Tubes

Quantity	Description
1	Secondary mirror
1	2" 10:1 dual speed focuser
3	Scope feet
4	M6 knob screws (25mm long) with wing nuts for the truss tube and upper ring connection
8	M6 knob screws for the truss tube and mirror box connection
4	M6 knob screws for the ALT bearing reinforcement cross bars
1	Velcro tape to hold the sling
3	Brass wire to evenly separate cell support bars
1	Nylon sling belt
6	Mirror Cell Support Pad

Options

1	9 x 50 finder scope and bracket (optional)
1	Shroud (optional)
1	Truss Tube Carry Bag (optional)
1	5-star artificial star (optional)
1	Mirror Box Cover (optional)

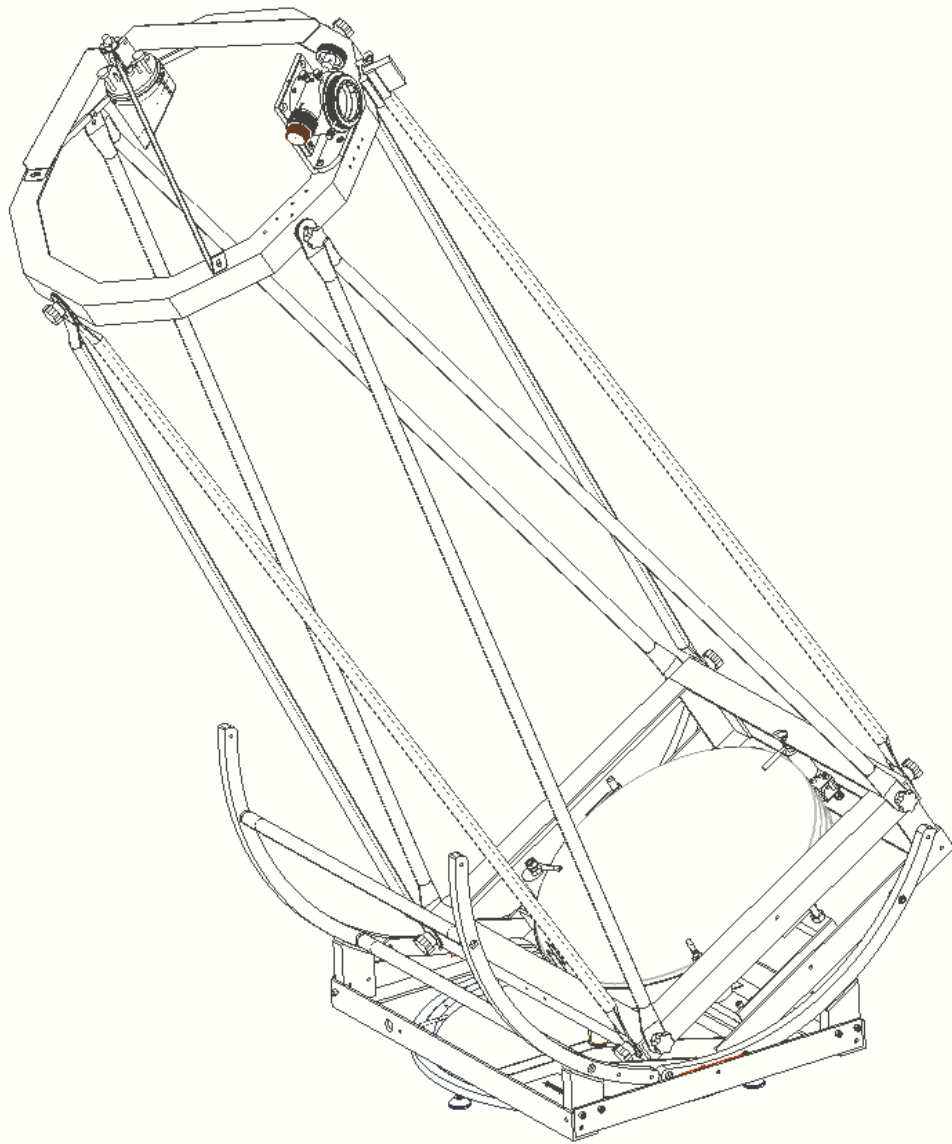

UL16

2. Assembly

Now that you have unpacked the boxes and familiarized yourself with all of the parts in front of you, it's time to begin assembly. You'll need a Regular screwdriver, a Phillips screwdriver, a set of metric hex keys (1.5, 2, 2.5, 3, 4, and 5mm), two 6-inch (150mm or smaller) adjustable crescent wrenches, and a scissor.



Tools Required (Not provided)

2.1 Install the Secondary Mirror

2.1.1 Install the Secondary to the diagonal holder

The secondary baffle is made of the thin aluminum, please handle the mirror and the baffle with care! First, remove the 5 small side screws holding the secondary baffle. Open the baffle slightly, and carefully slide the secondary mirror into the baffle from the back; let the mirror lightly held by the baffle's rim. Then place the fiber fill behind the secondary mirror to support the mirror. You should place enough fiber packing behind the secondary to hold it snugly in place but don't over-pack it; otherwise, it will cause distortion of the secondary mirror. Then re-install the 5 small screws to secure the baffle and the secondary mirror to the back plate.

You may need to add some spacers between the baffle and the back plate if the baffle is too tight.

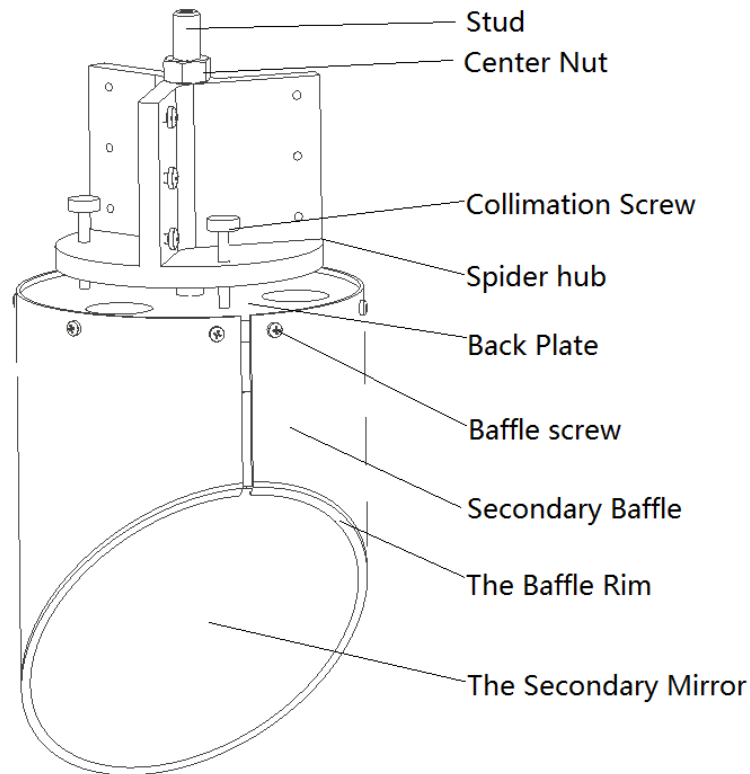

2.1.2 Assembly of the Secondary Cage

Please note that most screws needed for the installation are already installed on the parts for easy identification.

- Attach the three spider wings to the spider holder
- Attach the three spider wings to the upper ring
- Attach the focuser L bracket to the upper ring and tighten the screws
- Attach the focuser to the L bracket and tighten the screws
- Attach the secondary holder with the secondary mirror (installed and cured)
- Roughly adjust the center bolt and the orientation of the secondary holder until the secondary mirror is centered by being viewed from the focuser draw tube
- Adjust and tighten the three collimation screws.

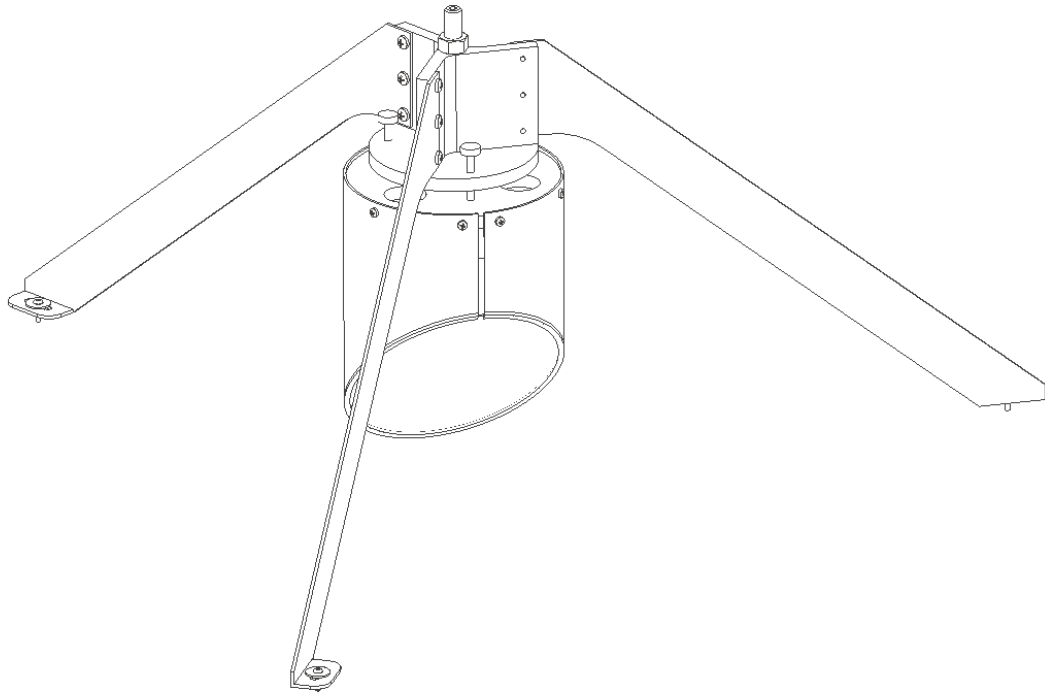

Attach the three spider wings to the spider hub

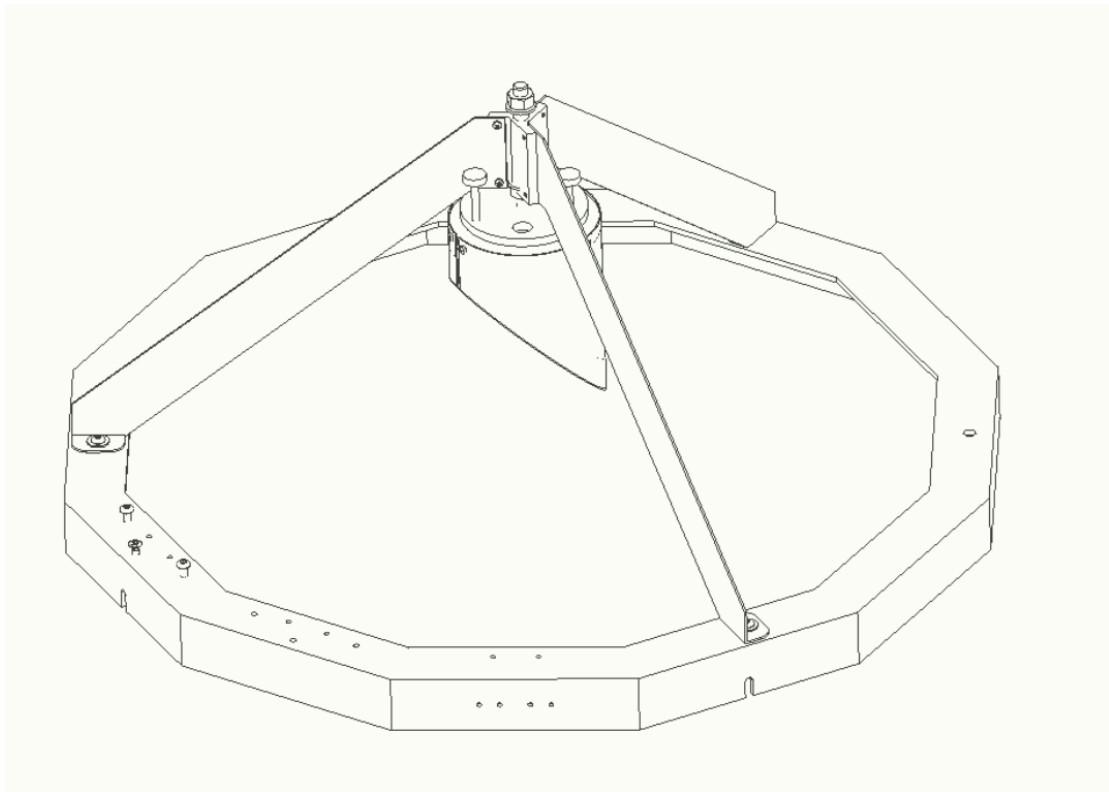

Attach the three spider wings to the upper ring

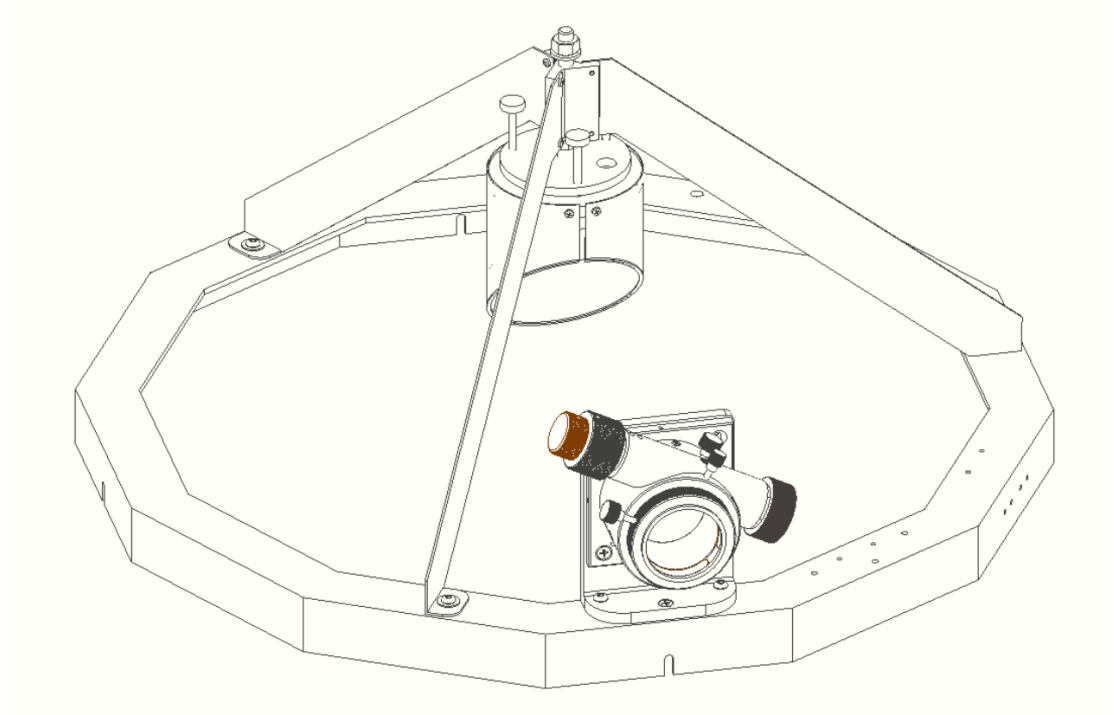

Attach the focuser L bracket and the focuser to the upper ring

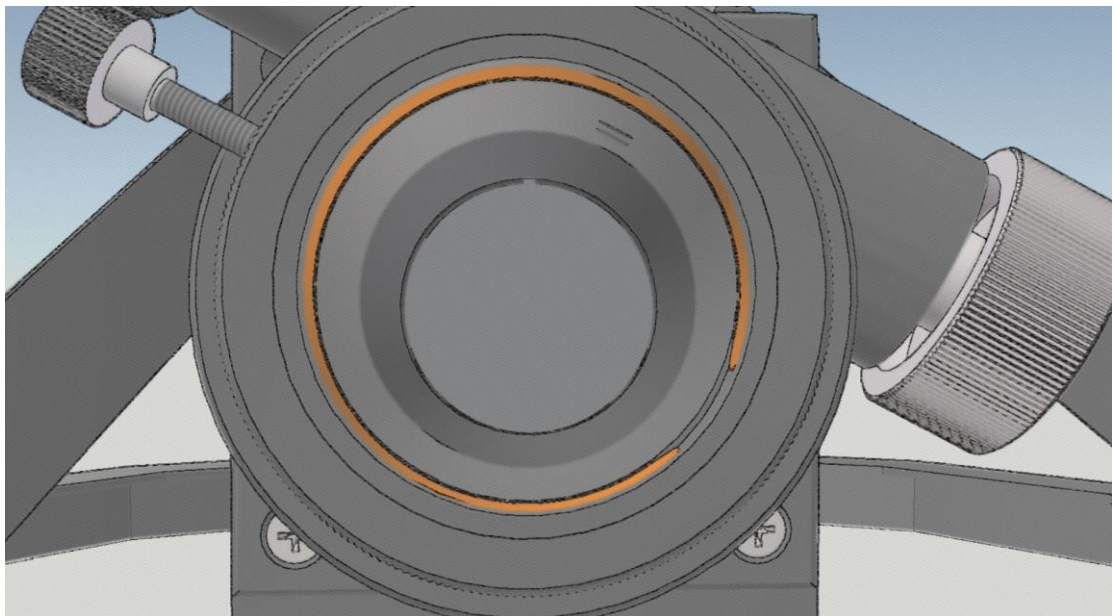

Center the secondary in the focuser draw tube

2.2 Assembly of the Dobsonian Rocker

The UL16 base is shipped assembled, the only thing you need to do is to install the three plastic feet. Make sure to use the wingnut to lock the three feet in their position.

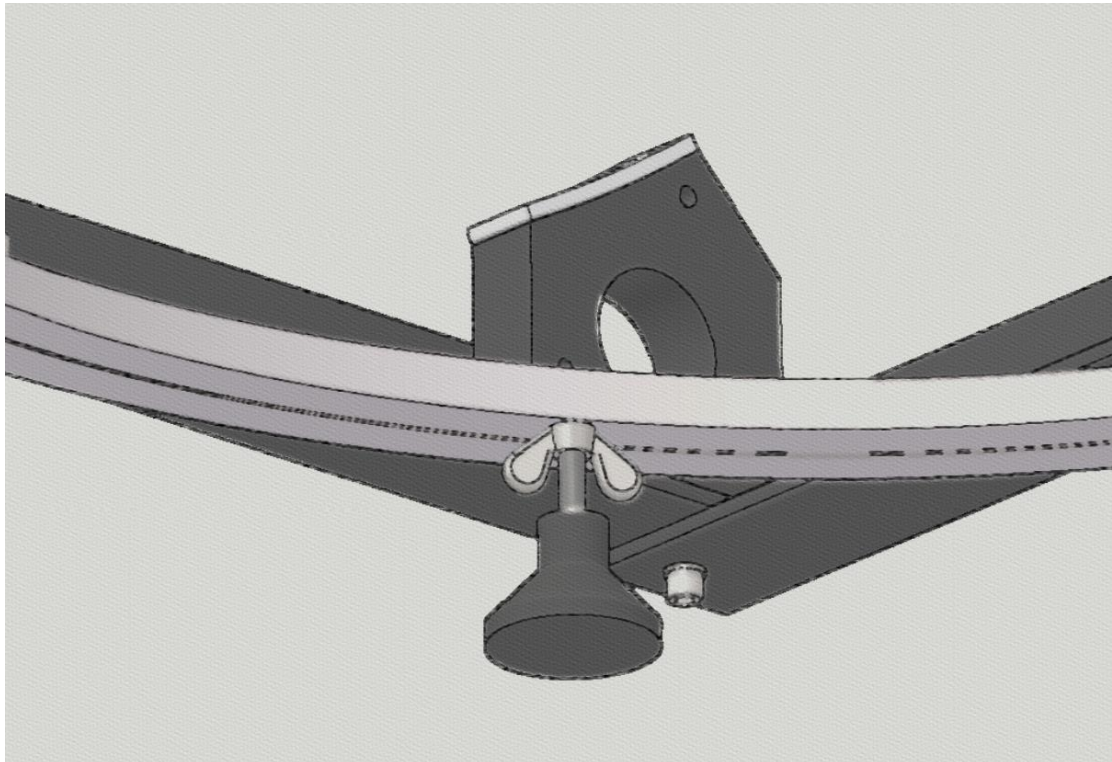
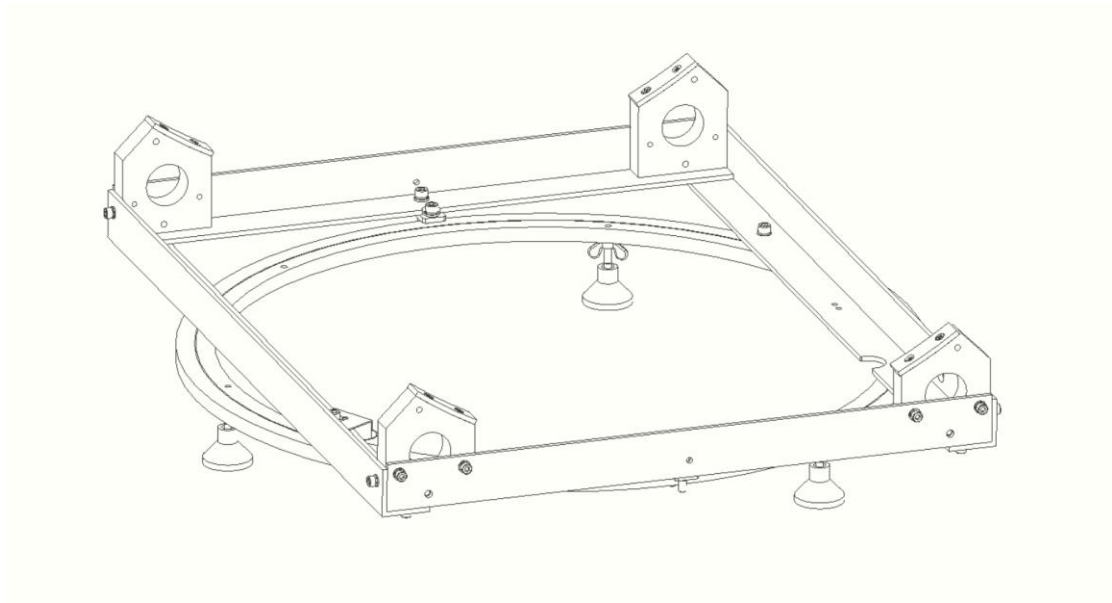

2.3 Assembly of the Mirror Box

The mirror box is very much assembled already; but you do need to install the ALT bearings and load the primary mirror into the mirror box.

Before installing the primary mirror, you need to perform the following tasks:

- Attach the 6 adhesive scratch protectors to the three support bars - two per bar - so the mirror glass never touches bare metal
- Attach the 3 brass wires to regulate the support bars

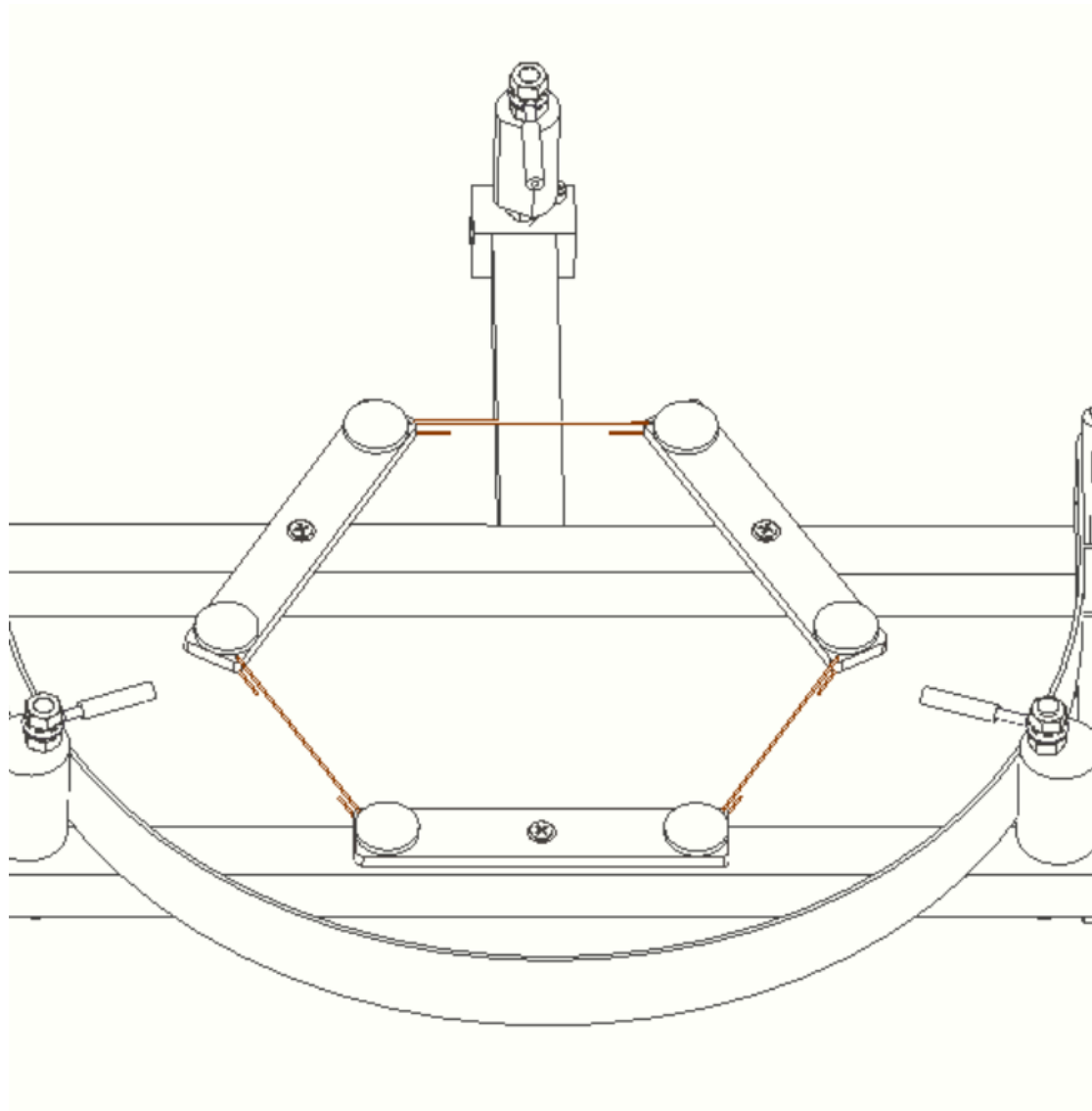

Bend 3 brass wire to the following shape, with the center portion to be about 93.5 mm (a bit longer is OK, but all three should be the same length as much as possible).

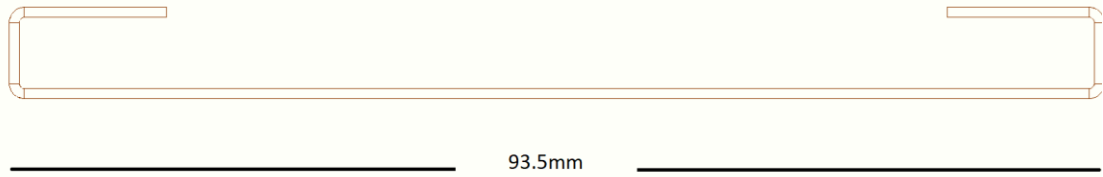

Insert the brass wires into the small holes on the support bars, and then bend the head portions to lock the brass wires in the position.

Please note that the mirror cell in the UL16 features a push-pull design. However, for safety during shipping, the three M5 pushing screws are not pre-installed; they are in a bag with an assortment of screws. This is to prevent any potential damage during transit. Upon receiving your system, you will need to install these three M5 locking screws, which are located adjacent to the collimation knobs.

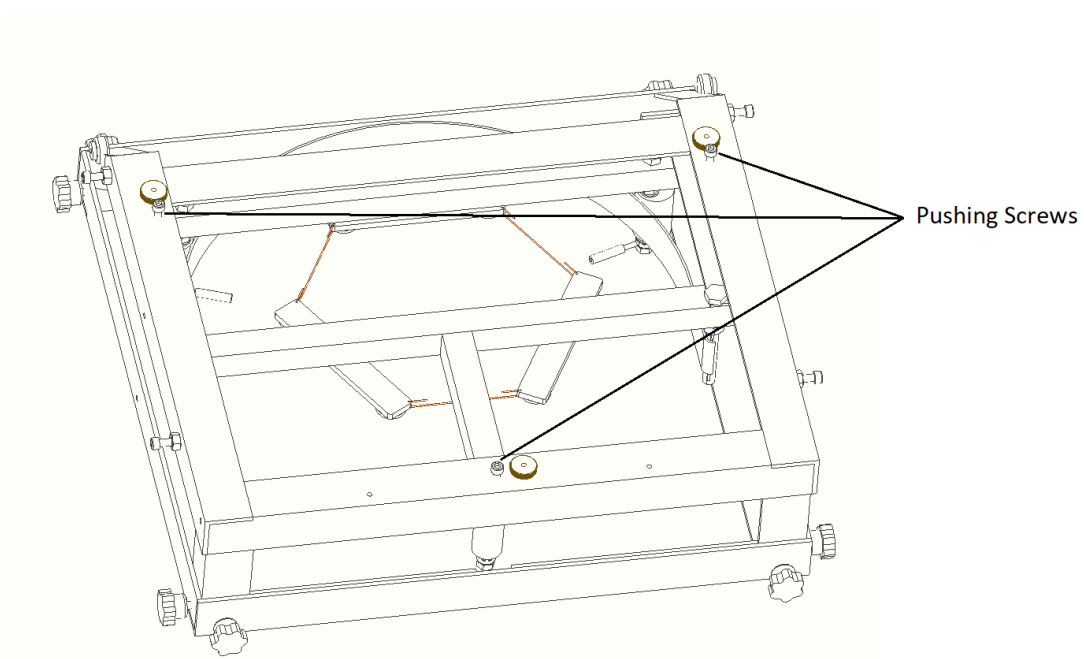

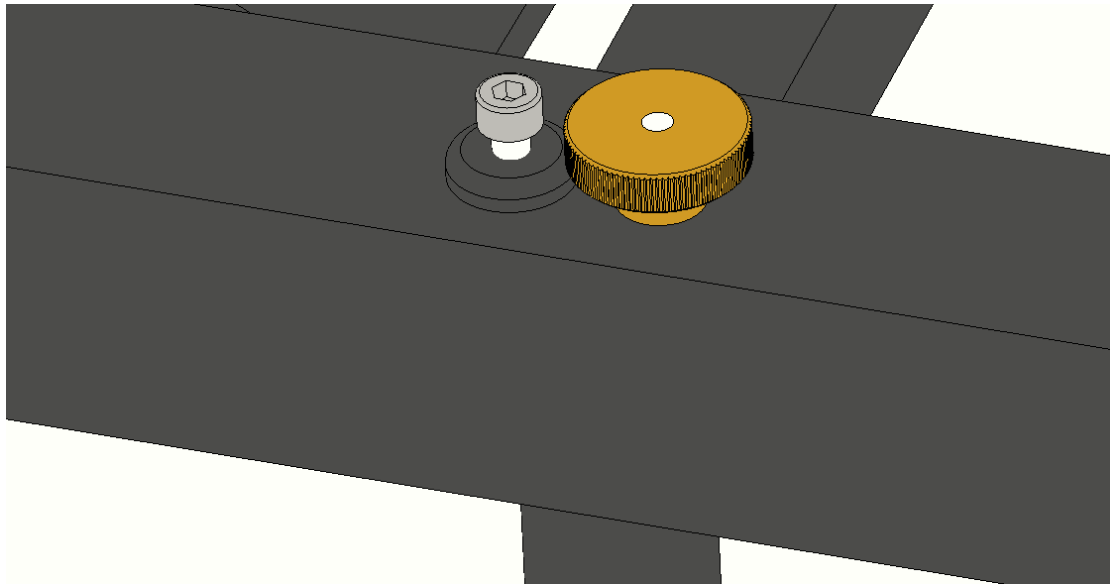

The primary mirror is shipped in its own box. Once the primary mirror is installed in the mirror box, there will be no need to remove the mirror until cleaning is necessary. However, for shipping, long distance transportation, and the long time storage, the primary mirror should be packed tightly in its original package.

2.3.1 Center Spot The Primary Mirror.

The mirror has been centered spot already!

2.3.2 Install the ALT Bearings

Each ALT (altitude) bearing is made of two curved pieces that look very similar - a **lower portion** and a **top portion** - which connect to form one complete arc. **Only the lower portion bolts to the mirror box.**

How to tell them apart: the lower portion has **two countersunk (stepped) holes** whose spacing matches the mounting holes on the mirror box exactly. The top portion does not have these holes.

1. Join the lower and top portions of one bearing together to form the full curved arc, securing them with the provided screws.
2. Lay the mirror box on its side on a padded surface.
3. Bolt the lower portion to that side of the mirror box, driving the screws through its two countersunk holes into the matching holes in the box.
4. Turn the mirror box over and repeat for the second ALT bearing on the other side.

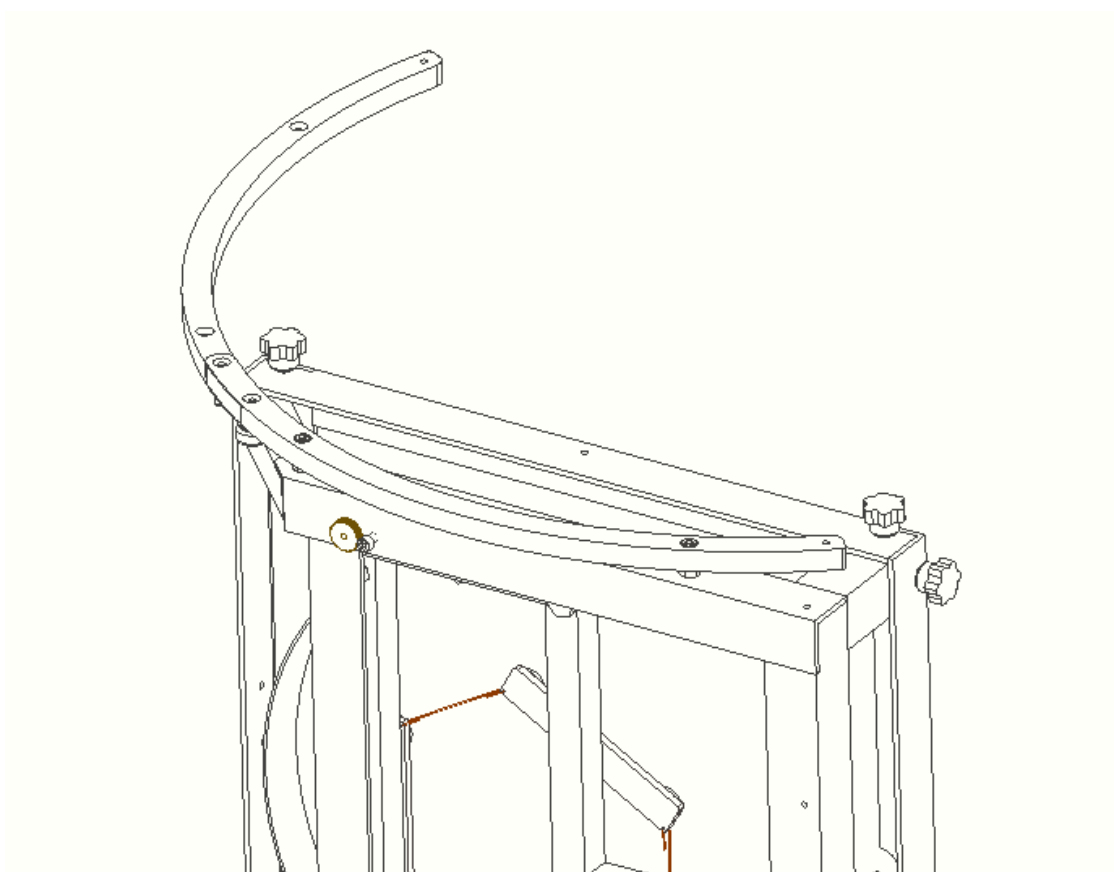
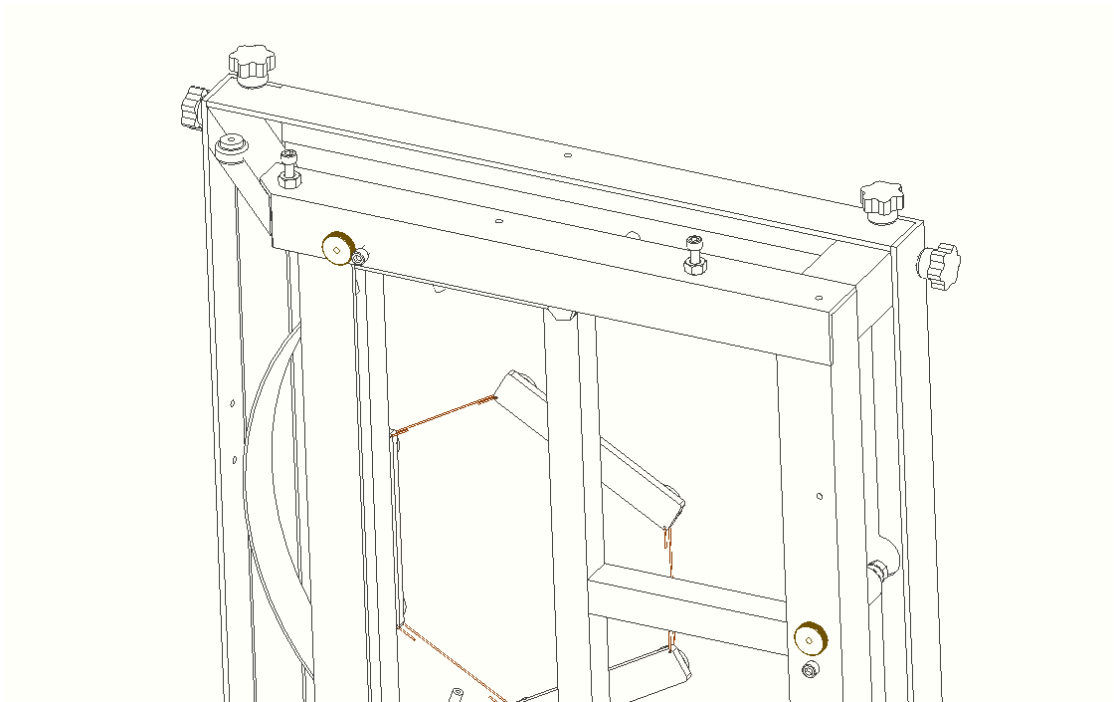

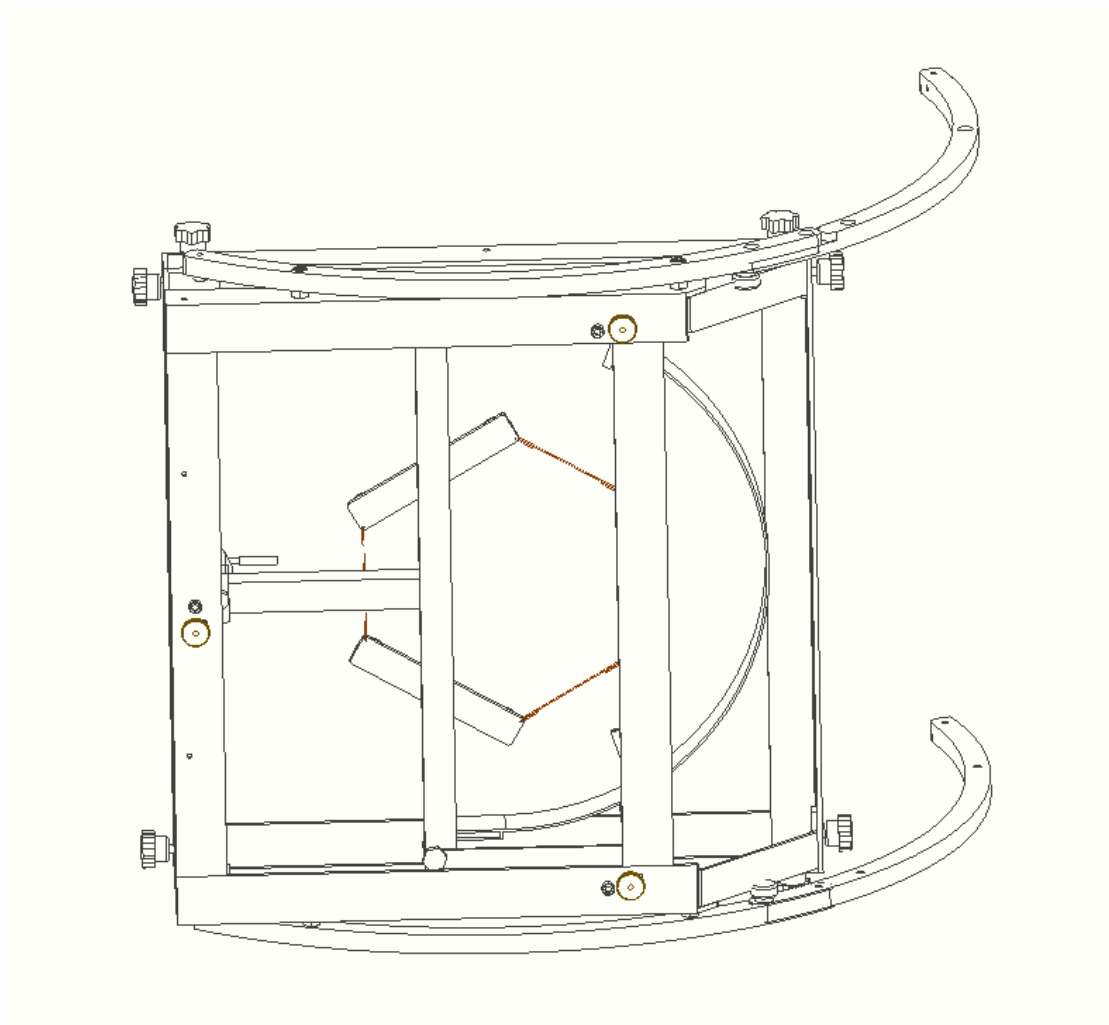

Place the mirror box carefully onto the Rocker/Ground board. The two front ALT bearing cross bars are included for extra reinforcement of the ALT bearing. Using them is optional - most users do not need them. If you want the additional support, install them as below:

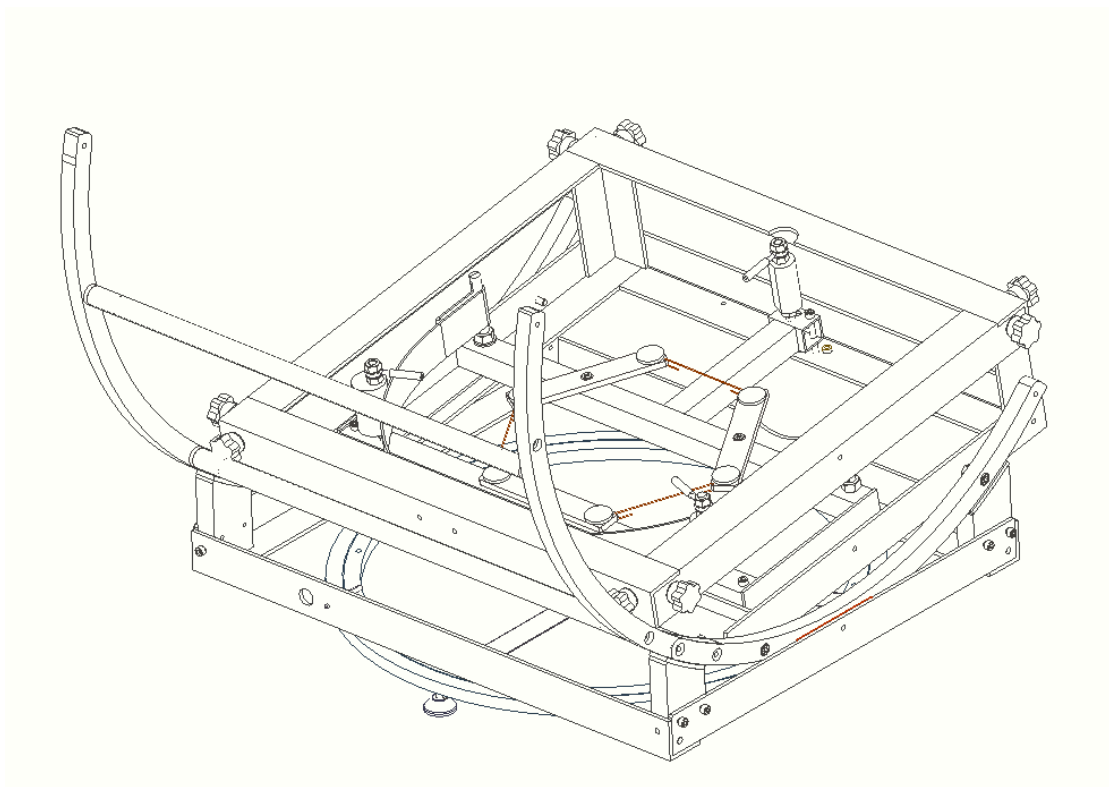

2.3.3 Install the Primary Mirror

Rotate the three eccentric side pins to make room for the primary mirror. Loosen the locknuts on the top of the mirror clips and turn them aside.

Use a flat head screwdriver to open the split bolts, and insert the sling into the slot. Also loosen the nuts on the two split bolts that hold the sling. Stretch the sling loosely around the two lower side pins.

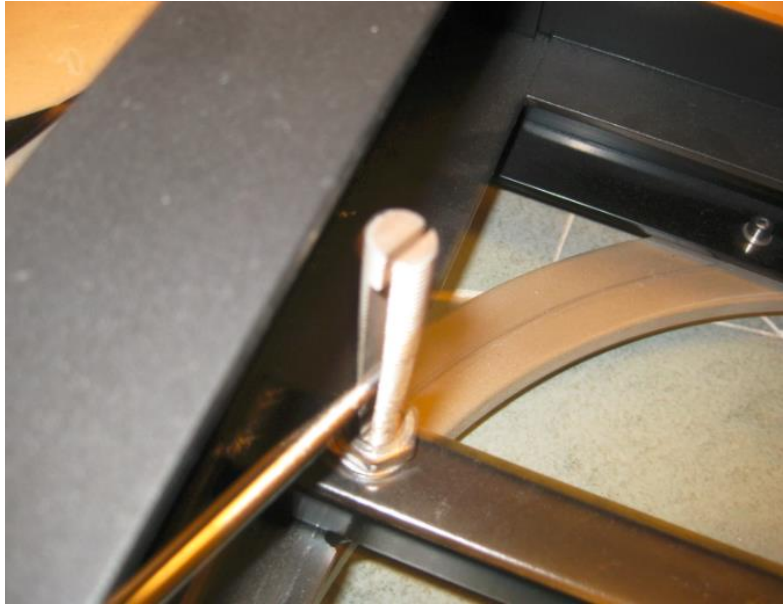

Open the split bolt



Insert the sling



Lock the mirror box to the rocker with nylon strips.

Make sure that all the mirror support bars are evenly placed in the cell. Pick up the mirror and place it into the mirror cell. Check that the mirror is centered and wiggles it a bit to ensure that the cell parts are moving freely and adjusted to the float of the mirror.

Viewed from the above, the primary mirror should be well centered in the mirror box:

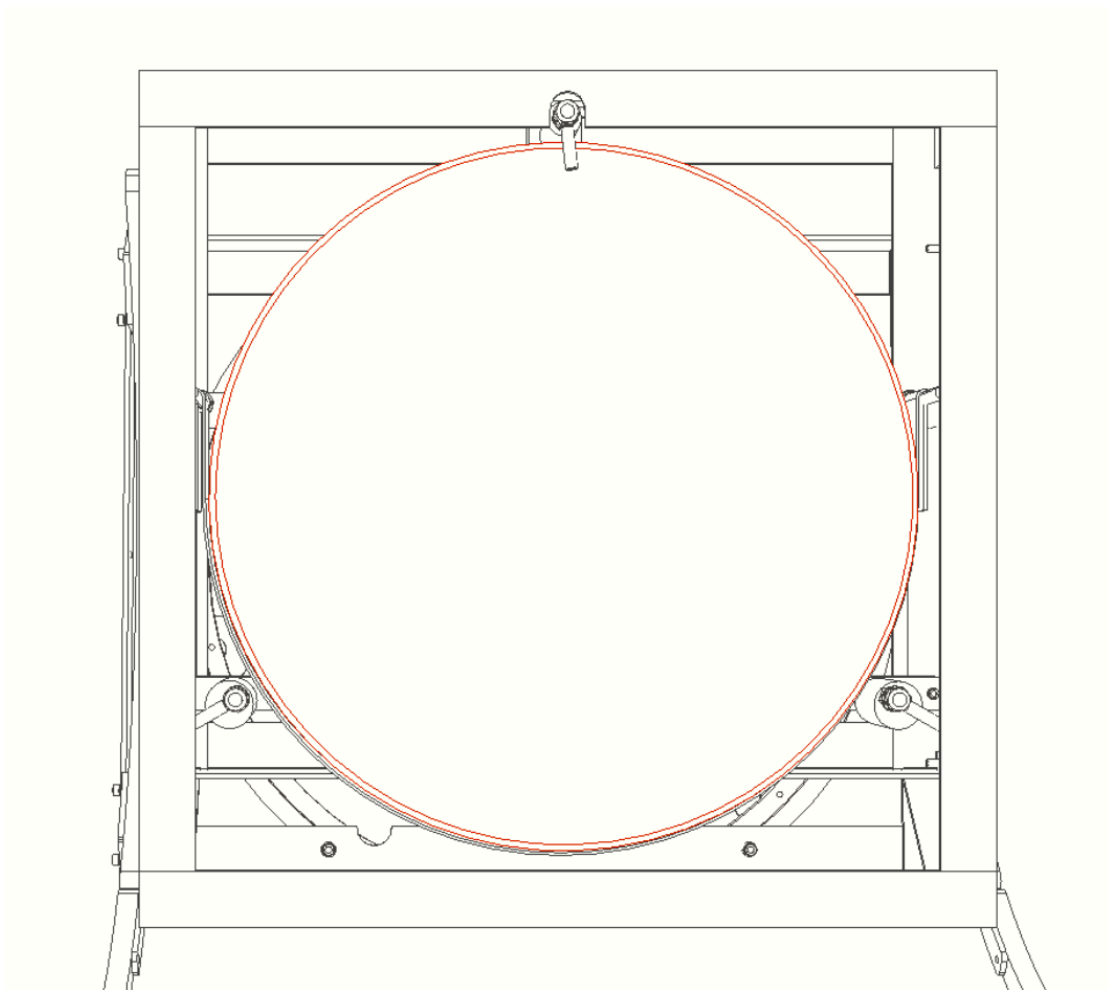

Use a flat head screwdriver to open the split bolts, and insert the sling into the slot. Stretch the sling loosely around the two lower side pins.

1. **Secure the Mirror Box:** Ensure the mirror box is secured to the rocker.
2. **Position the Mirror Support Bars:** Verify that the three mirror support bars are evenly distributed within the mirror cell.
3. **Install the Mirror:** Carefully place the mirror into the mirror cell. Center the mirror and gently wiggle it to confirm that the cell components move freely and are properly adjusted to accommodate the mirror's float.
4. **Install the Sling:** Position the sling between the side pin and the mirror's edge. Adjust the two lower pins so that there is a gap between the sling encircling the mirror and the side pins.
5. **Side Pin Adjustment:** Ensure the side pins do not contact the mirror during observation. If the primary mirror touches the pins, reposition

the sling and adjust the side pins as needed. Securely tighten the nuts holding the side pins.

6. **Mirror Protection Clips:** Adjust the mirror protection clips so they hover 3-6mm above the mirror surface, without touching the mirror. Secure the clips over the mirror and tighten the top lock nuts.
7. **Sling and Magic Nylon Tape:** At this stage, the sling should be loosely fitted around the mirror. Leave the sling loose for now; final adjustments will be made after the telescope is fully assembled.

Apply a short piece of the provided magic nylon tape at the lowest part of the mirror, which will rest in the bottom of the sling. Ensure the sling is centered, with equal portions of the mirror above and below it. The magic tape prevents the sling from slipping off when the telescope is pointed upwards.

The bottom side pins should not contact the mirror/sling during observation. **However, the top side pins should lightly touch/support the mirror.**

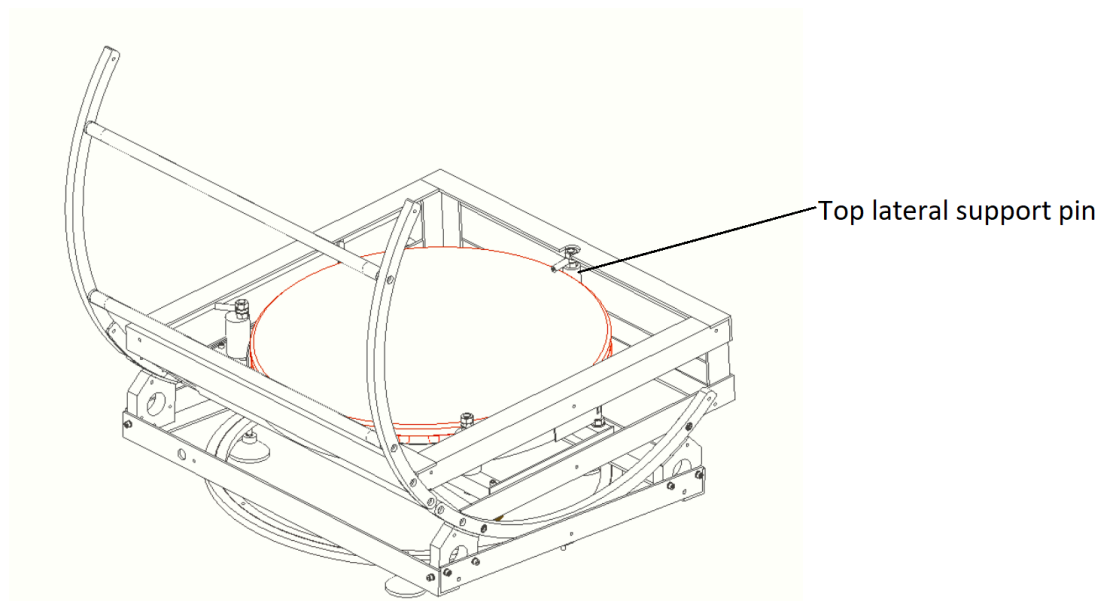

2.4 Install The Truss Tubes and Secondary Cage

2.4.1 Installation of the Truss Tubes

1. **Asymmetric Truss Tube Ends:** The ends of the truss tubes are asymmetrically shaped to enable connection in opposite orientations. This design helps to avoid interference between the tubes during assembly.
2. **Primary Mirror Protection:** Ensure that the primary mirror is fully enclosed and protected. A mirror box cover is recommended for this purpose.

3. **Truss Tube Connection:** Attach each pair of truss tubes using an M6 knob screw, and secure it with an M6 wing nut. This connection should be made on the side of the tube that has multiple holes. These multiple holes allow for adjustments in the overall tube assembly length, which is necessary to accommodate slight variations in the primary mirror's focal length. Typically, the second hole from the top is the recommended starting point for this connection.
4. **Attaching Truss Tubes to Mirror Box:** Finally, connect each pair of truss tubes to the mirror box using a M6 knob screw.

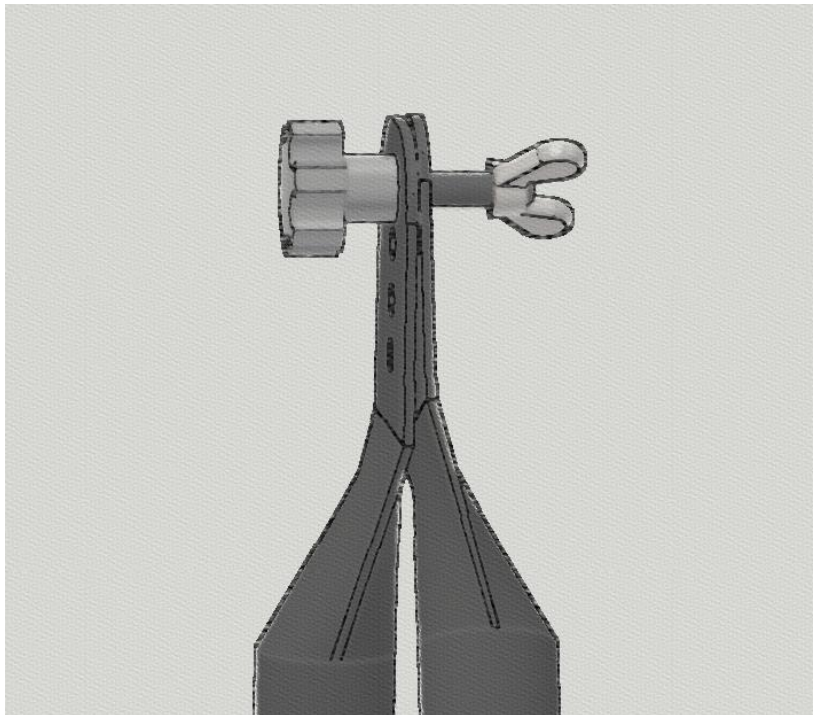

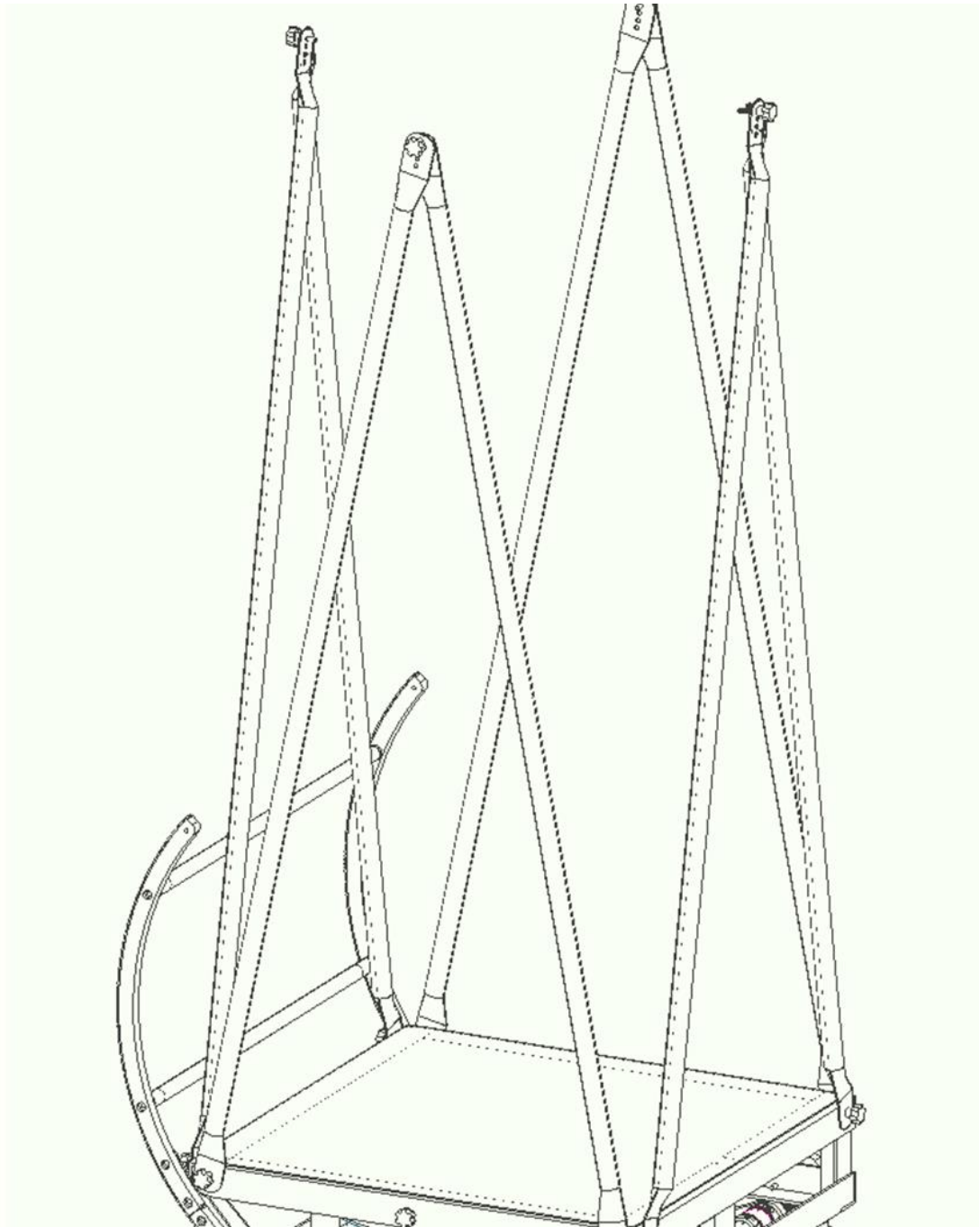

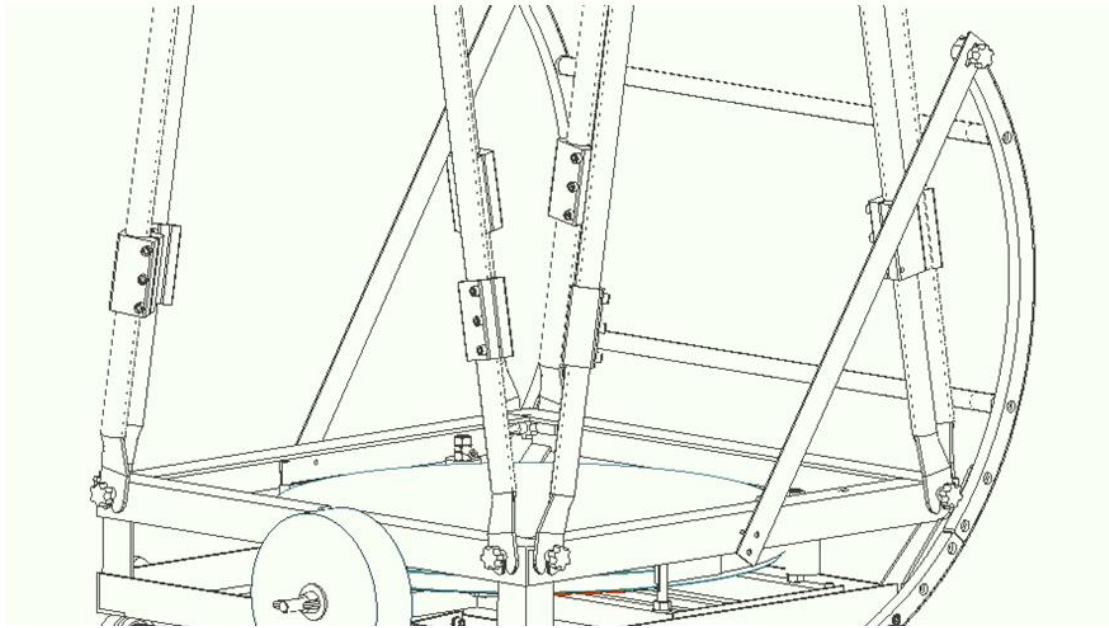

UL16 f/5 with sectional truss tubes (the counter weight shown is not provided)

2.4.2 Installation of the Secondary Mirror Cage

Make sure that the primary mirror is fully protected with a mirror box cover. Then carefully install the upper ring on to the top of the truss tubes. Tighten all the top and bottom truss tubes locking screws once the upper ring is positioned correctly.

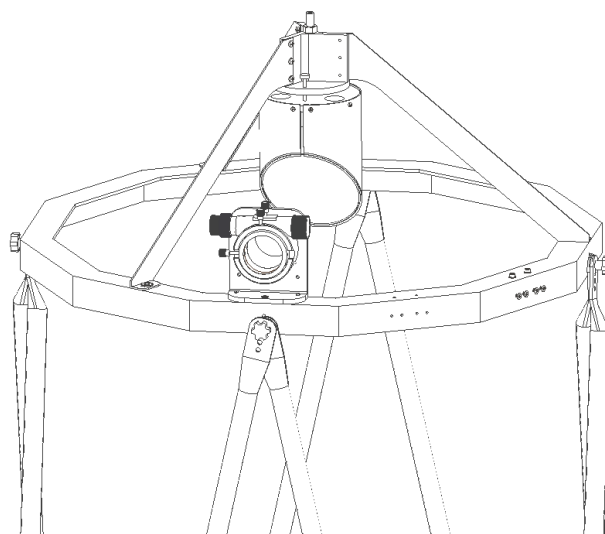

2.4.3 Installation of the Optional Finder Scope

Use 2 provided (hexagon or cross) socket sunk head screws to mount the finder scope base to the upper ring.

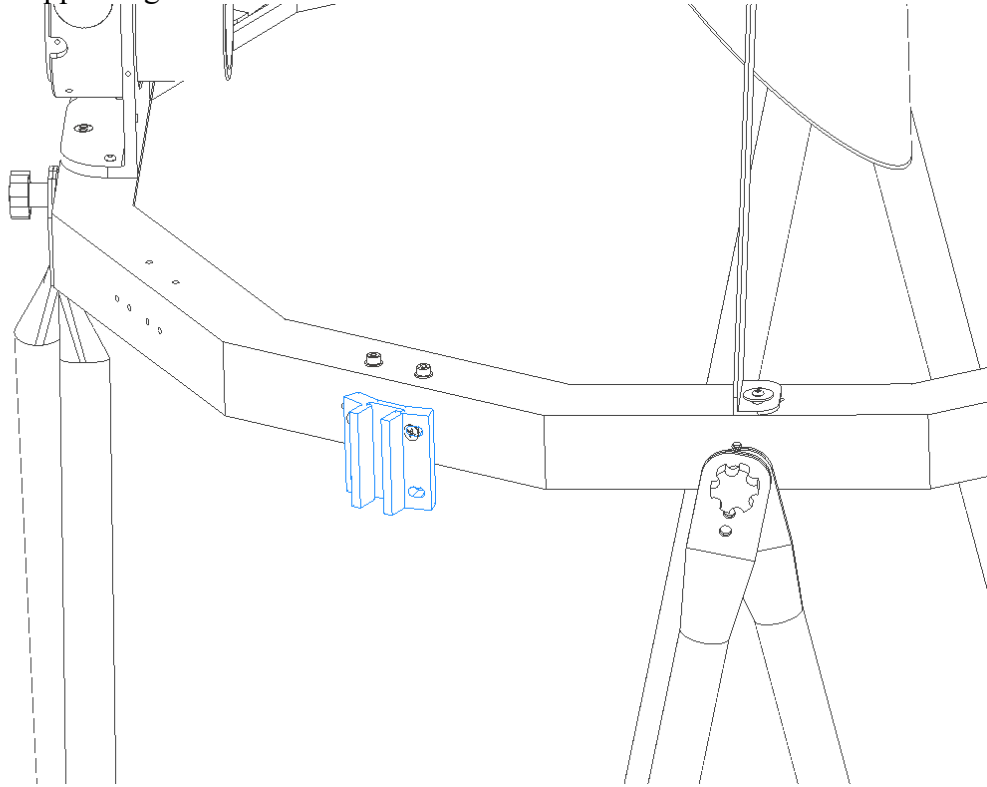

2.5 Adjust the Sling

After UL16 is fully assembled, the sling must be adjusted.

The primary mirror must be supported in the sling and not by the side pins. Point UL16 about 60° above the horizon in manual mode, an angle from which you can comfortably reach and adjust the collimation screws.

You will need to use two wrenches to adjust the sling. Make sure that the sling is hung through the slot on the left (or right) split bolt. Just wrap one or two turns on this side. To do this, rotate the head of the bolt with one wrench and hold the opposing nut with other wrench. Lock it tight.

Now go to the sling bolt on the other side. Hold the bolt head with one wrench and loosen the opposing nut. Turn the bolt to wrap the sling until the mirror lifts off the two lower pins. Raise the mirror until it almost touches the upper side pin.

Lock the bolt in this position by tightening the lock nuts. Check to make sure that the mirror is indeed suspended on the sling by pushing on the back of the mirror with your fingertips. With UL16 in a nearly horizontal position, you should be able to move the mirror off the floatation cell support bars easily.

If the mirror tilts against one of the side pins, loosen the retaining nuts and rotate that pin away from mirror until there is a few mm gap between the mirror and the pin.

The mirror must be supported by the sling and not by the side pins.

3. Collimate the Optics.

Collimating a telescope can seem intimidating at first, but with practice, it becomes a straightforward process. Regularly check the collimation of your telescope, especially if it's transported frequently, to ensure the best possible views of the night sky.

Keep the primary mirror covered during step 1. Point the telescope to an angle about 60 degrees above the horizontal during collimation steps 1-3.

Ensure that your scope's collimation doesn't shift when pointed at different altitudes. Tighten all locking nuts and screws properly along the entire optical path:

- The focuser is tightly locked in its square base
- The focuser square base is tightly locked onto the rotator
- The rotator is tightly locked onto the upper ring
- All three spider vanes are tightly locked onto the spider hub and the upper ring
- The three collimation screws for the secondary mirror need to be properly tightened after the collimation
- All knob screws for all the truss tubes need to be tightened properly
- The three primary mirror locking screws need to be tightened properly

Two positions have been provided to mount the focuser for the convenience.

However, for the maximum collimation stability, and in particular for the heavy load, the focuser should be installed right on top of the Truss Tubes.

Step 1: Center the secondary mirror along the axis of the focuser drawtube.

For this step, use a simple collimation cap (or sight tube). Insert the cap into the focuser and look through the peephole of the sight tube at the secondary mirror. If you don't have a collimation cap or sight tube, you can approximate by eyeballing from a distance, positioning your eye centered with the drawtube.

The secondary mirror should appear round and be exactly centered within the sight tube. If it is, then Step 1 is complete. If not, adjustments might be needed for either the secondary holder, the focuser, or both.

Begin by checking and adjusting the secondary holder. If the error is vertically up or down, adjust the central bolt that connects the holder to the spider hub.

If the discrepancy is to either side of the focuser (perpendicular to the optical axis), examine if the secondary holder is centered within the upper ring. If it's off-center, adjust the spider wing's pulling screws until it's centered.

Step 2: Adjust the tilt of the secondary mirror to direct the focuser's axis toward the center of the primary mirror. To start, remove the cover from the primary mirror.

For this step, you'll need a laser collimator. Insert the laser collimator into the focuser tube. Adjust the three secondary mirror collimation screws until the laser beam is centered on the primary mirror's center spot.

A slight misalignment in the secondary mirror is typically not problematic. As long as the pointing error remains within 1 or 2 percent of the main mirror's diameter, it won't cause any noticeable differences.

Step 3: This step is crucial. Here, you'll adjust the tilt of the primary mirror to ensure the returning laser beam centers on the centre of the laser collimator.

Manipulate the three primary collimation screws and their adjacent locking screws to align the laser's returning beam with the collimator's faceplate.



The primary mirror is not yet collimated.



The primary mirror is not yet collimated.



The primary mirror is collimated by laser collimator.

Step 4: Star-Testing Your Collimation

To accurately collimate your telescope, the star test is an effective method. Here's how to do it:

1. **Selecting a Star:** Choose a moderately bright star for this test.
2. **Aiming the Telescope:** Point your telescope at the selected star.
3. **Defocusing the Star:** Slowly defocus the telescope until the star forms a distinct 'donut' shape. This shape is a ring of light with a central dark spot, which is the shadow of the secondary mirror.
4. **Analyzing the Donut Shape:** Observe the donut. A perfectly collimated telescope will show a centered dark spot. If the central spot is off-center, it indicates misalignment.
5. **Adjusting the Primary Mirror:** If the donut's hole is not centered, gently adjust the primary mirror's collimation screws. Make small adjustments: tighten one screw while slightly loosening the opposite screw to maintain even pressure. Aim to move the defocused star image towards the thicker side of the donut.
6. **Re-centering the Star:** After each adjustment, re-center the star in your telescope's field of view by re-aiming the telescope. The position of the star may shift slightly with each collimation adjustment.
7. **Repeating the Process:** Continue this process - adjusting, re-centering, and observing the defocused star - until the donut shape appears symmetrical with the central hole perfectly centered.

8. **Final Symmetry Check:** Once the donut appears symmetrical, fine-tune your focus to check the concentric rings around the star. Proper collimation is indicated by centered and symmetrical rings.

Remember, atmospheric conditions can affect the appearance of the star's image. Conduct this test on a night with stable and clear atmospheric conditions for the best results.

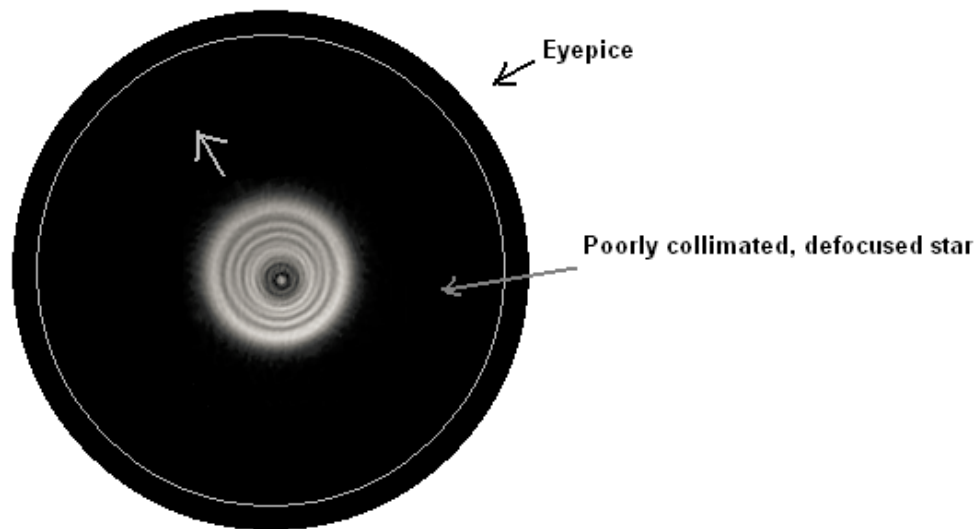

It's advisable to carry out this procedure at the onset of each observing session. Additionally, you should check the collimation sporadically throughout the night. This is crucial because factors like temperature variations or routine handling could cause shifts in your telescope's components, potentially affecting the collimation.

4. Care and Maintenance

4.1 ALT Bearing Surface Maintenance

You should use the Pledge® cleaning wipes /spray (or other furniture wax) to clean and condition the ALT bearing surface before use it for the first time. Then, you should do it about every 6 months to achieve the optimal performance.



4.2 Scope Storage

Your telescope should be stored in a clean, dry, and dust-free environment, protected from rapid changes in temperature and humidity. It is not advisable to store the telescope outdoors. Storing it in your garage or shed might be acceptable, but this is not recommended. We highly recommend storing the secondary cage and the mirror box in our optional waterproof nylon storage bag. While the bag is sufficiently large, avoid storing the rocker/ground board with the mirrors in the bag for extended periods. The potential evaporation of lubricants used in the azimuth bearing, especially under high temperatures, can be harmful to the mirror's coating.

4.3 Mirror Cleaning

You should not have to clean the mirror often. The best thing you can do to keep your mirror is to prevent it from getting dirty in the first place! A simple air-blow cleaning, using an optical air dust blower is the next best thing you can do.

5. Specification

- Optical design : Reflector
- Optical diameter: Optical diameter: 406.4mm
- Focal length: 1829mm (f/4.5), 2032mm (f/5)
- Focal ratio: f/4.5, f/5
- Eyepiece height at zenith: 1690mm / 66.5" (f/4.5), 1890mm / 74.5" (f/5)
- Optics type : Parabolic
- Eyepieces: Not included
- Optical quality : Diffraction limited++ (Strehl 0.95+ for the primary mirror, 1/10 lambda or better for the secondary mirror)
- Finder scope : Not included

- Focuser : 2" dual-speed linear bearing Crayford
- Secondary mirror: 80 mm (f/4.5), 70mm (f/5)
- Secondary mirror obstruction by diameter: 19.7% (f/4.5), 17.3% (f/5)
- Secondary mirror obstruction by area: 3.9% (f/4.5), 3.0% (f/5)
- Mirror coatings: 96% Enhanced coating on both of the primary and secondary mirrors
- Tube material : 6063-T6 Aluminum Alloy tubes with black stainless steel knob screws; Aluminum Alloy main structure (OTA and mount) and structure steel mirror cell.
- Length of optical tube: ~72 in (f/4), ~79 in (f/4.5)
- Weight, optical tube: 55.0 lbs
- Weight, fully assembled: 65.0 lbs.
- Dawes Limit(arcsec): 0.29
- Rayleigh Limit(arcsec): 0.33
- Limiting Mag: 15.5
- Maximum Magnification: 800
- Other features: Sling lateral support and deluxe push-pull brass knob collimation screws
- Optional accessories:
 - 9x50 Finder,
 - Truss Carrying Bag
 - Shroud,
 - Wheelbarrow,
 - Vinyl foam Cushioned Grips
 - Mirror Cover
 - Scope Cover
 - GoTo+ Drive System
 - Wireless/USB DSC
- **Wireless DSC Ready!**

6. Limited Warranty

Hubble Optics (Optel Engineering Group Inc.), Seller, warrants to the original purchaser only, that goods sold will be free of material defects in design, materials and workmanship for a period of one year following the date of shipment by Seller to Buyer. Seller will repair or replace, or refund the purchase price as to, goods that do not conform to the foregoing warranty, provided the cause of the nonconformity does not arise from or relate to modification, misuse, or abuse by the customer, and provided a warranty claim, stating in writing and with reasonable particularity the claimed nonconformity, and the goods, are delivered to Seller within the one year period. Repair or replacement of the product or refund of the purchase price, at Seller's sole option, shall be the Buyer's exclusive remedies. Seller shall not be responsible for any indirect, special or consequential damages arising from use of the

products. This warranty is given in lieu of any other warranties, express or implied, including of performance, merchantability, fitness for particular purpose, or arising from course of dealing or usage of trade. Goods subject to this warranty must be shipped postage pre-paid by Buyer to the Seller. Some states do not allow the exclusion or limitation of incidental or consequential damages, so the above limitations may not apply to you. This warranty gives you specific legal rights, and you may also have other rights, which vary from state to state.

7. Technical Support

Hubble Optics (Optel Engineering Group Inc.) will provide the support for the basic operations outlined in this document by email. You will receive a response, generally within 24 hours.